



# The Federation of Motor Sports Clubs of India

## 2009 FMSCI Technical Regulations – 4W

Member of



Federation Internationale  
de l' Automobile



Federation Internationale  
de Motocyclisme



Indian Olympic Association

---

FMSCI, A25, Krishna Towers, 50 Sardar Patel Road, Chennai 600113 Ph : +91 44  
22352673 / 22355304 / 64506665 Fax : 22351684 email : [fmsci@vsnl.com](mailto:fmsci@vsnl.com)  
Website : [www.fmsci.in](http://www.fmsci.in)

*With effect from 1st January 2009*

## **ARTICLE 1: CLASSIFICATION**

### **1.1 Categories and groups**

The cars used in competition shall be divided up into the following categories and groups:

Category I:

- Group N: Production Cars
- Group N+: Modified Production Cars

### **1.2 Cubic capacity classes**

The cars will be divided up into the following classes according to their cubic capacity:

1. From 801cc upto and including 1100cc. GROUP N
2. From 1101cc upto and including 1400cc. GROUP N
3. From 1101cc upto and including 1400cc. GROUP N+
4. From 1401cc upto and including 1600cc. GROUP N
5. From 1401cc upto and including 1600cc. GROUP N+
6. From 1601cc upto and including 2000cc GROUP N+

Unless otherwise specified in special provisions imposed by the FMSCI for a certain category of events, the organisers are not bound to include all the above-mentioned classes in the Supplementary Regulations and, furthermore, they are free to group two or more consecutive classes, according to the particular circumstances of their events.

No Class can be subdivided.

## **ARTICLE 2: DEFINITIONS**

### **2.1 General conditions**

2.1.1) Series Production cars (Category I):

Cars of which the production of a certain number of identical examples (see definition of this word hereinafter) within a certain period of time has been verified at the request of the manufacturer, and which are destined for

normal sale to the public (see this expression). Cars must be sold in accordance with the homologation form.

2.1.2) XXX.

2.1.3) XXX

2.1.4) **Identical cars:**

Cars belonging to the same production series and which have the same bodywork (outside and inside), same mechanical components and same chassis (even though this chassis may be an integral part of the bodywork in case of a monocoque construction).

2.1.5) **Model of car:**

Car belonging to a production-series distinguishable by a specific conception and external general lines of the bodywork and by an identical mechanical construction of the engine and the transmission to the wheels.

2.1.6) **Normal sale:**

Means the distribution of cars to individual purchasers through the normal commercial channels of the manufacturer.

2.1.7) **Homologation:**

Is the official certification made by the FMSCI that a minimum number of cars of a specific model has been made on series-production terms to justify classification in Production Cars (Group N) of these regulations.

It must be established in accordance with the special regulations called "Regulations for homologation", laid down by the FIA. Homologation of a series-produced car will become null and void 7 years after the date on which the series-production of the said model has been stopped (series-production under 10 % of the minimum production of the group considered).

The homologation of a model can only be valid in one group, Production Cars (Group N) / Touring Cars (Group A)

### 2.1.8) Homologation forms:

All cars recognised by the FMSCI will be the subject of a descriptive form called homologation form on which shall be entered all data enabling identification of the said model.

This homologation form defines the series as indicated by the manufacturer.

According to the group in which the competitors race, the modification limits allowed for FMSCI National competition for the series, are stated in FMSCI Technical Regulations I, II, III, IV.

The presentation of the forms at scrutineering and/or at the start may be required by the organisers who will be entitled to refuse the participation of the entrant in the event in case of non-presentation. Likewise, if a Group A car fitted with a kit variant (see below) concerning the chassis/shell is used, the original certificate supplied at the time of mounting by a centre approved by the manufacturer must be presented.

Should the date for the coming into force of a homologation form fall during an event, this form will be valid for that event throughout the duration of the said event.

With regard to Production Cars (Group N), apart from the specific form for this group, the Touring Cars (Group A) form must also be submitted.

In case of any doubt remaining after the checking of a model of car against its homologation form, the scrutineers should refer either to the maintenance booklet published for the use of the make's distributors or to the general catalogue in which are listed all spare parts.

In case of lack of sufficient accurate documentation, scrutineers may carry out direct scrutineering by comparison with an identical part available from a concessionaire.

It will be up to the competitor to obtain the homologation form concerning his car from his ASN.

#### **Description:**

A form breaks down in the following way:

- 1) A basic form giving a description of the basic model.

2) At a later stage, a certain number of additional sheets describing "homologation extensions", which can be "variants", or "errata" or "evolutions".

a - Variants (VF, VP, VO, VK)

These are either supply variants (VF) (two suppliers providing the same part for the manufacturer and the client does not have the possibility of choice), or production variants (VP) (supplied on request and available from dealers), or option variants (VO) (supplied on specific request), or "kits" (VK) (supplied on specific request).

b - Erratum (ER)

Replaces and cancels an incorrect piece of information previously supplied by the constructor on a form.

c - Evolution (ET, ES)

Characterises modifications made on a permanent basis to the basic model (complete cessation of the production of the car in its original form in the case of the evolution of the type (ET), or sporting evolution (ES) intended to render a model more competitive.

**Use:**

1) Variants (VF, VP, VO, VK)

The competitor may use any variant or any part of a variant as he wishes, only on condition that all the technical data of the vehicle, so designed, conforms to that described on the homologation form applicable to the car, or expressly allowed by Appendix J of the FIA. The combination of several VOs on the following parts is prohibited: Turbocharger, brakes and gearbox. For example, the fitting of a brake caliper as defined on a variant form is only possible if the dimensions of the brake linings, etc. obtained in this way, are indicated on a form applicable to the car in question. (For Production Cars (Group N), see also Art. 254-2 of the FIA).

As far as kit-variants (VK) are concerned, they may not be used only under the conditions indicated by the manufacturer on the homologation form. This concerns in particular those groups of parts which must be considered as a whole by the competitor, and the specifications which are to be respected, if applicable.

## 2) Evolution of the type (ET)

(For Production Cars - Group N, see also Art. 254-2 of the FIA) The car must comply with a given stage of evolution (independent of the date when it left the factory), and thus an evolution must be wholly applied or not at all.

Besides, from the moment a competitor has chosen a particular evolution, all the previous evolutions should be applied, except where they are incompatible.

For example, if two brake evolutions happen one after another, only that corresponding to the date of the stage of evolution of the car will be used.

## 3) Sporting evolution (ES)

Since the ES form refers to a previous extension, or to the basic form, the car must correspond to the stage of evolution corresponding to this reference; moreover, the Sporting Evolution must be applied in full.

### 2.1.9) Mechanical components:

All those necessary for the propulsion, suspension, steering and braking as well as all accessories whether moving or not which are necessary for their normal working.

### 2.1.10) Original or series parts:

A part which has undergone all the stages of production foreseen and carried out by the manufacturer of the vehicle concerned, and originally fitted on the vehicle.

No abrasive material may be used on any component, which would alter the surface finish of the original part.

### 2.1.11) Composite:

Material formed from several distinct components, the association of which provides the whole with properties which none of the components taken separately possesses.

## **2.2 Dimensions**

Perimeter of the car seen from above: The car as presented on the starting grid for the event in question.

## **2.3 Engine**

2.3.1) Cylinder capacity:

Volume V generated in cylinder (or cylinders) by the upward or downward movement of the piston(s).

$$V = 0.7854 \times b^2 \times s \times n$$

Where: b = bore

s = stroke

n = number of cylinders

2.3.2) XXX

2.3.3) Cylinder block:

The crankcase and the cylinders.

2.3.4) Intake manifold:

In the case of a carburettor induction system:

- Part collecting the air-fuel mixture from the carburettor(s) and extending to the cylinder head gasket face.

In the case of a single-valve injection induction system:

- Part extending from the body of the butterfly valve inclusive to the cylinder head gasket face, collecting and regulating the air or the air-fuel mixture flow.

In the case of a multi-valve injection induction system :

- Part extending from the butterfly valves inclusive to the cylinder head gasket face, collecting and regulating the air or the air-fuel mixture flow.

In the case of a diesel engine :

Unit mounted to the cylinder head, which distributes the air from one inlet or a sole duct to the cylinder head ports.

2.3.5) Exhaust manifold:

Part collecting together at any time the gases from at least two cylinders from the cylinder head and extending to the first gasket separating it from the rest of the exhaust system.

2.3.6) For cars with a turbocharger, the exhaust begins after the turbocharger.

2.3.7) Sump:

The elements bolted below and to the cylinder block which contain and control the lubricating oil of the engine.

These elements must not have any mounting part of the crankshaft.

2.3.8) Engine compartment:

Volume defined by the structural envelope closest to the engine.

2.3.9) Lubrication by dry sump:

Any system using a pump to transfer oil from one chamber or compartment to another, to the exclusion of the pump used for the normal lubrication of the engine parts.

2.3.10) Static gasket for mechanical parts

The only function of a gasket is to ensure the sealing of at least two parts, fixed in relation to each other. The distance between the faces of the parts separated by the gasket must be less than or equal to 5 mm.

2.3.11) Exchanger:

Mechanical part allowing the exchange of calories between two fluids. For specific exchangers, the first-named fluid is the fluid to be cooled and the second-named fluid is the fluid that allows this cooling. e.g. Oil/Water Exchanger (the oil is cooled by the water).

2.3.12) Radiator:

This is a specific exchanger allowing liquid to be cooled by air. Liquid / Air Exchanger.

### 2.3.13) Intercooler or Supercharging Exchanger:

This is an exchanger, situated between the compressor and the engine, allowing the compressed air to be cooled by a fluid. Air / Fluid Exchanger.

## **2.4 Running gear**

The running gear includes all parts totally or partially unsuspended.

### 2.4.1) Wheel:

Flange and rim.

By complete wheel is meant flange, rim and tyre.

### 2.4.2) Friction surface of the brakes:

Surface swept by the linings on the drum, or the pads on both sides of the disc when the wheel achieves a complete revolution.

### 2.4.3) Mac Pherson suspension:

Any suspension system in which a telescopic strut, not necessarily providing the springing and/or damping action, but incorporating the stub axle, is anchored on the body or chassis through single attachment point at its top end, and pivots at its bottom end either on a transversal wishbone locating it transversally and longitudinally, or on a single transversal link located longitudinally by an anti-roll bar, or by a tie rod.

### 2.4.4) Twist beam axle :

Axle made of two longitudinal trailing arms, each attached to the bodysell through a joint, and rigidly attached one to the other through a transversal structure, the torsion stiffness of which is low compared to its bending stiffness.

## **2.5 Chassis - Bodywork**

### 2.5.1) Chassis:

The overall structure of the car around which are assembled the mechanical components and the bodywork including any structural part of the said structure.

2.5.2) Bodywork:

- externally: all the entirely suspended parts of the car licked by the airstream.
- internally: cockpit and boot.

Bodywork is differentiated as follows:

- 1) Completely closed bodywork
- 2) Completely open bodywork
- 3) Convertible bodywork with the hood in either supple (drop-head) or rigid (hardtop) material.

2.5.3) Seat:

The two surfaces making up the seat cushion and seatback or backrest.

Seatback or backrest:

Surface measured from the bottom of a normally seated person's spine.

Seat cushion:

Surface measured from the bottom of the same person's spine towards the front.

2.5.4) Luggage compartment:

Any volume distinct from the cockpit and the engine compartment inside the vehicle. These volumes are limited in length by the fixed structures provided for by the manufacturer and/or by the rear of the seats and/or, if this is possible, reclined at a maximum angle of 15° to the rear. These volumes are limited in height by the fixed structures and/or by the detachable partitions provided for by the manufacturer, or in the absence of these, by the horizontal plane passing through the lowest point of the windscreen.

2.5.5) Cockpit:

Structural inner volume which accommodates the driver and the passengers.

2.5.6) Bonnet:

Outer part of the bodywork which opens to give access to the engine.

2.5.7) Mudguard:

A mudguard will be considered to be the area defined according to drawing 251-1.

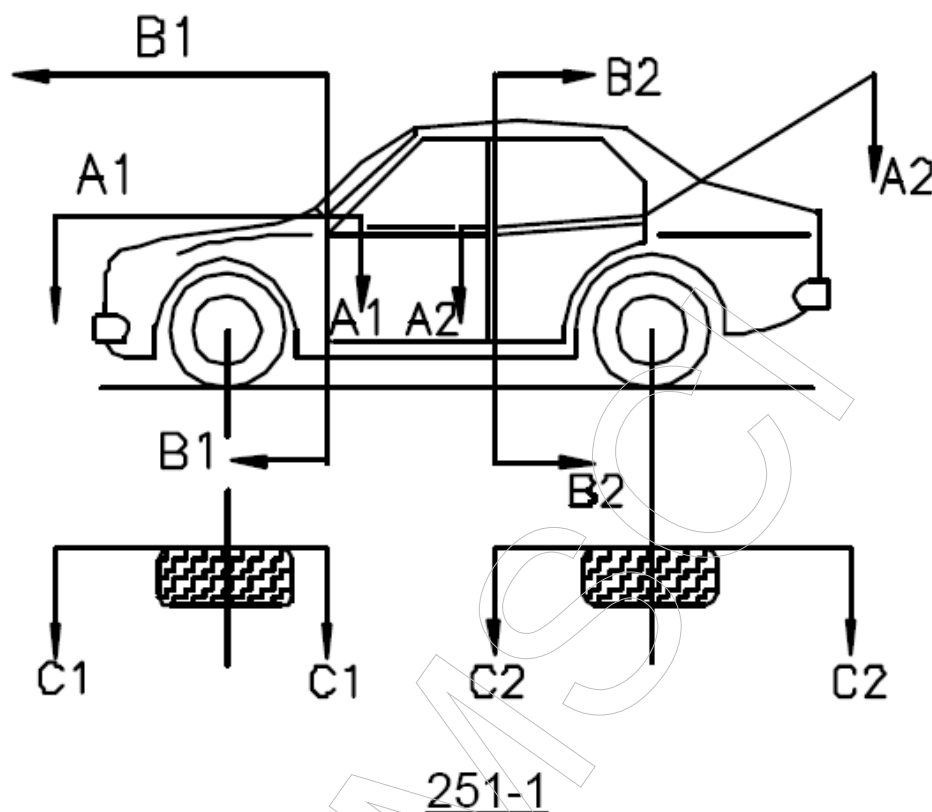

Front mudguard: The area licked by the airstream, defined by the inner face of the complete wheel of the standard car (C1/C1), the front edge of the front door (B1/B1), and situated below the plane parallel to the door sills and tangent to the lower corners of the visible part of the windscreen (A1/A1).

Rear Mudguard: the area licked by the airstream, defined by the inner face of the complete wheel of the standard car (C2/C2), the front edge of the rear door (B2/B2), and situated below the lower edge of the visible part of the window of the rear side door, and below the tangent to the lower corner of the visible part of the rear windscreen and to the lower rear corner of the visible part of the side window of the rear door (A2/A2).

In the case of a two-door car, B1/B1 and B2/B2 will be defined by the front and rear of the same door.

2.5.8) Louvres:

Combination of inclined slats that conceal an object situated behind them while allowing air to pass through.

<b>2.6 Electrical system</b>
------------------------------

Headlight: Any signal the focus of which creates an in-depth luminous beam directed towards the front.

<b>2.7 Fuel tank</b>
----------------------

Any container holding fuel likely to flow by any means whatsoever towards the main tank or the engine.

<b>2.8 Automatic Gearbox</b>
------------------------------

- This is made up of a hydrodynamic torque converter, a box with epicyclic gears equipped with clutches and multi-disc brakes and having a fixed number of reduction gears, and a gear change control. The gear change can be achieved automatically without disconnecting the engine and gearbox, and thus without interrupting the engine torque transmission.

- Gearboxes with continually variable transmission are considered as automatic gearboxes with the particularity of having an infinite number of reduction ratios.

<b>ARTICLE 3:</b>
-------------------

<b>3.1 Homologation forms</b>
-------------------------------

The presentation of the forms at scrutineering and/or at the start will be required by the organisers who will be entitled to refuse the participation of the entrant in the event in case of non-presentation.

**The form presented must imperatively be printed: On stamped/watermarked paper from an ASN.**

**\*\* END \*\***

**2009 FMSCI Technical Regulations – II  
General Prescriptions**

*With effect from 1st January 2009*

**ARTICLE 1: GENERAL REMARKS**

**1.1 Modifications**

All modifications are forbidden unless expressly authorised by the regulations specific to the group in which the car is entered or by the general prescriptions below or imposed under the chapter "Safety Equipment".

The components of the car must retain their original function.

BLUE PRINTING OF ENGINES IS NOT PERMITTED.

(No abrasive material may be used, which may cause a change to the surface finish of engine components (e.g. cylinder head ports, and inlet manifolds, pistons, connecting rods, cylinder head combustion chambers, carburetors, valves, and valve guides) - the finish of the component should be as supplied by the manufacturer.) SLEEVING OF THE BORE IS PERMITTED, SO LONG AS THE HOMOLOGATED DIAMETER IS RESPECTED.

**1.2 Application of the general prescriptions**

The general prescriptions must be observed in the event that the specifications of Production Cars (Group N) do not lay down a more strict prescription.

**1.3 Material**

The use of a material which has a specific yield modulus greater than 40 Gpa/g/cm<sup>3</sup> is forbidden, with the exception of plugs, exhaust coatings, water pump turbo joints, brake pads, brake calliper piston coatings, rolling elements of bearings (balls, needles, rollers), electronic components and sensors, parts weighing less than 20 g and all coatings with a thickness less than or equal to 10 microns.

The use of a metallic material which has a specific yield modulus greater than 30 Gpa/g/cm<sup>3</sup> or of which the maximum specific UTS is greater than 0.24 Mpa/kg/m<sup>3</sup> for non-ferrous material and 0.30 Mpa/kg/m<sup>3</sup> for ferrous

materials (i.e. 80% iron) is forbidden for the making of all the parts that are free or homologated as an Option Variant.

Ti-6Al-4V ASTM grade 5 type titanium alloy (5.5 < Al < 6.75, C max 0.10, 3.5 < V < 4.5, 87.6 < ti < 91) is authorised, except for certain parts for which titanium is expressly forbidden.

No turning part of a turbocharger or of any equivalent supercharging system (except the rolling parts of the bearings) may be made from ceramic material or have a ceramic coating.

These restrictions do not concern the parts homologated with the standard vehicle.

The use of magnesium alloy sheet metal with a thickness less than 3 mm is prohibited.

**1.4** It is the duty of each competitor to satisfy the Scrutineers and the Stewards of the meeting that his automobile complies with these regulations in their entirety at all times during the event.

**1.5** Damaged threads can be repaired by screwing on a new thread with the same interior diameter ("helicoil" type).

**1.6** XXX

**1.7** "Free" part

"Free" means that the original part, as well as its function(s), may be removed or replaced with a new part, on condition that the new part has no additional function relative to the original part.

## **ARTICLE 2: DIMENSIONS AND WEIGHT**

### **2.1 Ground clearance**

No part of the car must touch the ground when all the tyres on one side are deflated.

This test shall be carried out on a flat surface under race conditions (occupants on board).

## **2.2 Ballast**

It is permitted to complete the weight of the car by one or several ballasts provided that they are strong and unitary blocks, fixed by means of tools with the possibility to fix seals, placed on the floor of the cockpit, visible and sealed by the scrutineers.

Application: GROUP N +

No kind of ballast is authorised in Production Cars (Group N).

In rallies, however, the carrying of tools and spare parts for the car in the cockpit and/or inside the engine bay and/or inside the boot only will be allowed under the conditions laid down in article 253.

## **ARTICLE 3: ENGINE**

---

**3.1 XXX**

**3.2 XXX**

**3.3 XXX**

**3.4 XXX**

**3.5 XXX**

### **3.6 Exhaust system and silencer**

Even when the specific provisions for a group allow the replacement of the original silencer, the cars competing in an open-road event shall always be equipped with an exhaust silencer complying with the traffic regulations of the country (ies) through which the event is run.

For all cars used in Rallies and unless the limits imposed by the local authorities are lower, the noise level on the open road must not exceed 103 dB(A) for an engine rotation speed of 3500 rpm for petrol engines and 2500 rpm for diesel engines.

Moreover, adequate protection must be provided in order to prevent heated pipes from causing burns.

The exhaust system must not be provisional.

Exhaust gas may only exit at the end of the system.

Parts of the chassis must not be used to evacuate exhaust gasses.

### **3.7 Starting on board the vehicle**

Starter with electric or other source of energy on board operable by the driver when seated in the seat.

### **3.8 Cylinders**

For non-sleeved engines, it will be possible to repair the cylinders by adding material, but not parts. (Sleeving is permitted for Group N)

## **ARTICLE 4: TRANSMISSION**

All cars must be fitted with a gearbox including a reverse gear which must be in working order when the car starts the event, and be able to be operated by the driver when he is normally seated.

Welding or locking of the differential pin (spider pin) to the differential cage is permitted

## **ARTICLE 5: SUSPENSION**

Suspension parts made partially or entirely from composite materials are prohibited.

## **ARTICLE 6: WHEELS**

Wheels made partially or entirely from composite materials are prohibited.

### **Measuring wheel width:**

The width is to be measured with the wheel mounted on the car, on the ground, the vehicle in race condition, driver aboard, at any point along the circumference of the tyre, except in the area in contact with the ground.

When multiple tyres are fitted as part of a complete wheel, the latter must comply with the maximum dimensions for the Group in which these tyres are used (see article 255-5.4 and article 256-5).

## **ARTICLE 7: COACHWORK**

### **7.1 XXX**

### **7.2 Minimum inside dimensions**

If a modification authorised by FMSCI affects a dimension stated on the homologation form this dimension may not be retained as an eligibility criterion for the car.

### **7.3 Cockpit**

Inversion of the driving side is possible, on condition that the original car and the modified car are mechanically equivalent and that the parts used are provided by the manufacturer for such a conversion for the family concerned.

In particular, the steering column must pass through the bodyshell only via the hole made for that purpose by the manufacturer for the family concerned.

Only the following accessories may be installed in the cockpit: spare wheels, tools, spare parts, safety equipment, communication equipment, ballast (if permitted), windscreen washer water container).

Containers for helmets and tools situated in the cockpit must be made of non-inflammable material and they must not, in case of fire, give off toxic vapours.

The original fitting of the air bags may be removed, without modifying the appearance of the bodywork.

### **AIR SCOOPS**

'Air Scoops' may be fitted on roofs of cars solely for the purpose of ventilation provided it does not affect the safety of the original roof construction.

**7.4** All body panels of the vehicle must be at all times of the same material as those of the original homologated car and must be of the same material thickness as that of the original homologated car (tolerance  $\pm 10\%$ ).

## 7.5 Headlamp mounting and protection

The boring of holes in the front bodywork for light brackets is authorised, limited solely to mountings.

In rallies, non-reflecting protectors made from flexible material may be mounted on the headlamps; they must not protrude forwards beyond the headlamp glass by more than 10 cm.

**7.6** Any object of a dangerous nature (flammable products, etc.) must be carried outside the cockpit.

## 7.7 Mud flaps (in Rallies only)

It is possible to fit transversal mud flaps in conformity with the article below.

If transversal mud flaps are mandatory, this requirement must be mentioned in the supplementary regulations of the event.

In any case, transversal mud flaps are accepted under the following conditions:

- They must be made from flexible material.
- They must cover at least the width of each wheel, but at least one third of the width of the car (see drawing 252-6) must be free behind the front wheels and the rear wheels.

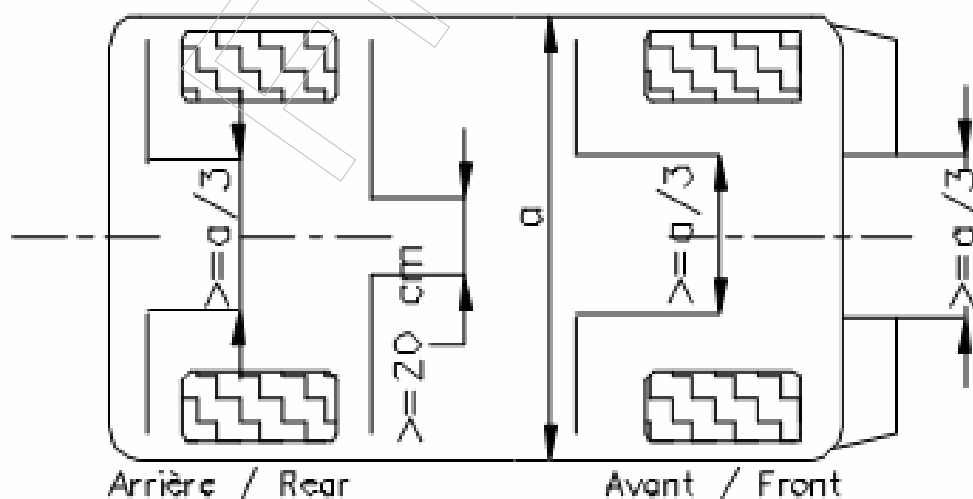

252-6

- There must be a gap of at least 20 cm between the right and left mud flaps in front of the rear wheels.
- The bottom of these mud flaps must be no more than 10 cm from the ground when the car is stopped, with nobody on board.
- Above and over the entire height of the tyre, at least 3/4 of the width of the tyre must be covered (seen from behind).
- In vertical projection, these mud flaps must not protrude beyond the bodywork.

Mud flaps to prevent splashing towards the front, made from flexible material, may be installed at the front of the vehicle, if the supplementary regulations of the event authorise them or impose them.

They must not protrude beyond the overall width of the vehicle, or beyond the original overall length by more than 10 cm, and at least one third of the width of the car must be free in front of the front wheels.

## **ARTICLE 8: ELECTRICAL SYSTEM**

### **8.1 Lighting**

A fog light may be changed for another light, and vice versa, provided that the original mounting remains the same.

### **8.2 Alternators and Alternator-starters**

The mounting of the alternators and alternator-starters are free.

### **8.3 Horn**

In rallies only, the noise level produced by the horn must be greater than or equal to 97 dB during at least 3 seconds, measured 7m in front of the vehicle.

## **ARTICLE 9: FUEL - COMBUSTIVE**

**9.1** The fuel must be commercial petrol which comes from a service station pump, without any additive other than that of a lubricant on current sale

**9.2** XXX

9.3 XXX

9.4 XXX

### 9.5 Tank ventilation

It is authorised to equip a tank with ventilation exiting through the car roof.

### 9.6 Installation of the FT3 1999, FT3.5 or FT5 tank

The FT3 1999, FT3.5 or FT5 tank may be placed either in the original location of the tank or in the luggage compartment.

There must be an orifice to evacuate any fuel which may have spread into the tank compartment.

The position and the dimension of the filler hole as well as that of the cap may be changed as long as the new installation does not protrude beyond the bodywork and guarantees that no fuel shall leak into one of the interior compartments of the car.

If the filler hole is situated inside the car, it must be separated from the cockpit by a liquid-tight protection.

## ARTICLE 10: BRAKES

Carbon brake discs are forbidden.

## ARTICLE 11: XXX

## ARTICLE 12: XXX

## Article 13: HELMETS

For all INRC championships and rally star cup or any other Indian cups – minimum requirement for helmets - ISI certification

**Article 14: Driving Suits:**

Minimum requirement:

FIA Homologated suits

OR

Fire retardant suit complying with EN531 Standards purchased from the following supplier:

TARA LOHIA PVT. LTD.  
13, Dr. Sarat Banerjee Road,  
Calcutta 700029,  
INDIA.  
Tel: +91-33-24660199 ;  
Fax: +91-33-24667165 ;  
email: info@taralohia.com ;

All suits will be sold with a certificate of authenticity and will have a serial number on the suit as well as the certificate, which must match. This certificate must be produced along with the driving suit at the time of scrutineering.

**\*\* END \*\***

**2009 FMSCI Technical Regulations – III : Safety Equipment**

*With effect from 1st January 2009*

**ARTICLE 1 :**

A car, the construction of which is deemed to be dangerous, may be excluded by the Stewards of the meeting.

**ARTICLE 2 :**

If a device is optional, it must be fitted in a way that complies with regulations.

**ARTICLE 3 : LINES AND PUMPS**

**3.1 Protection**

Fuel, oil and brake lines must be protected externally against any risk of deterioration (stones, corrosion, mechanical breakage, etc.) and internally against all risks of fire and deterioration.

Application: Optional for Group N if the series production fitting is retained.

Obligatory for all the Groups if the series production fitting is not retained or if the lines pass inside the vehicle and their protective covering has been removed.

In the case of fuel lines, the metal parts which are isolated from the shell of the car by non-conducting parts must be connected to it electrically.

**3.2 Specifications and installation**

Obligatory application if the series fitting is not retained.

Lines containing cooling water or lubricating oil must be outside the cockpit.

The fittings of fuel lines, lubricating oil lines and of those containing hydraulic fluid under pressure must be manufactured according to the specifications below:

- when flexible, these lines must have threaded, crimped or self-sealing connectors and an outer braid resistant to abrasion and flame (will not sustain combustion) ;
- minimum burst pressure measured at a minimum operating temperature of:
  - Fuel lines (except the connections to the injectors): 70 bar (1000 psi) 135°C (250°F).
  - Lubricating oil lines : 70 bar (1000 psi) 232°C (450°F).
  - Lines containing hydraulic fluid under pressure: 280 bar (4000 psi) 232°C (450°F).

If the operating pressure of the hydraulic system is greater than 140 bar (2000 psi), the burst pressure must be at least double the operating pressure.

Lines containing fuel or hydraulic fluid may pass through the cockpit, but without any connectors inside except on the front and rear bulkheads according to Drawings 253-59 and 253-60, and on the braking circuit and the clutch fluid circuit.

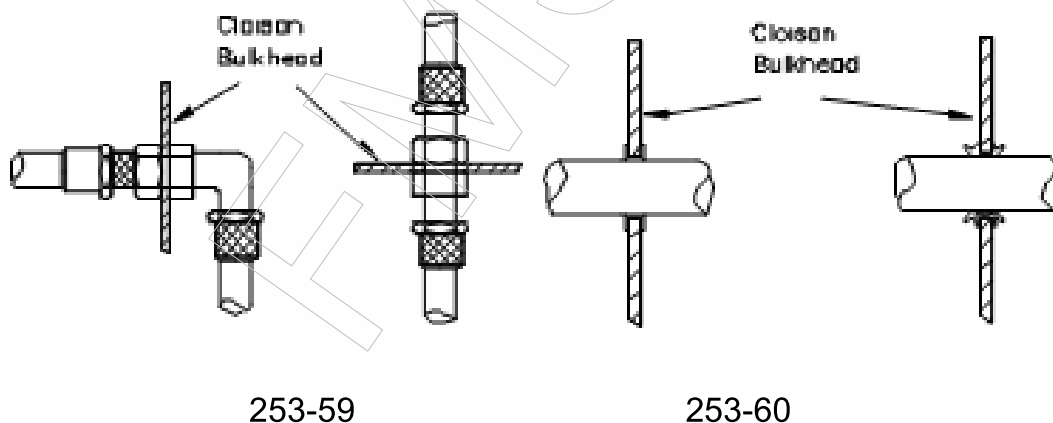

### 3.3 Automatic fuel cut-off

Recommended for all groups:

All fuel feed pipes going to the engine must be provided with automatic cut-off valves located directly on the fuel tank which automatically close all the fuel lines under pressure if one of these lines in the fuel system is fractured or leaks.

**Compulsory:**

All the fuel pumps must only operate when the engine is running, except during the starting process.

**3.4 Fuel cell ventilation**

XXX

**ARTICLE 4 : BRAKING SAFETY SYSTEM**

XXX

**ARTICLE 5 : ADDITIONAL FASTENERS**

At least two additional safety fasteners must be fitted for each of the bonnet and boot lids.

The original locking mechanisms will be rendered inoperative or removed.

Large objects carried on board the vehicle (such as the spare wheel, tool-kit, etc.) must be firmly fixed.

**ARTICLE 6 : SAFETY BELTS**

**6.1 Belts**

For rallies, two belt cutters must be carried on board at all times. They must be easily accessible for the driver and co-driver when seated with their harnesses fastened.

Wearing of two shoulder straps and one lap strap ; anchorage points on the shell: two for the lap strap, two or possibly one symmetrical about the seat for the shoulder straps.

These belts must be homologated by the FIA

On the other hand, it is recommended that for competitions which include public road sections, the belts be equipped with push button release systems.

The ASNs may homologate mounting points on the safety cage when this cage is being homologated, on condition that they are tested.

## 6.2 Installation

It is prohibited for the seat belts to be anchored to the seats or their supports.

- A safety harness may be installed on the anchorage points of the series car.

The recommended geometrical locations of the anchorage points are shown in Drawing n°253-61.

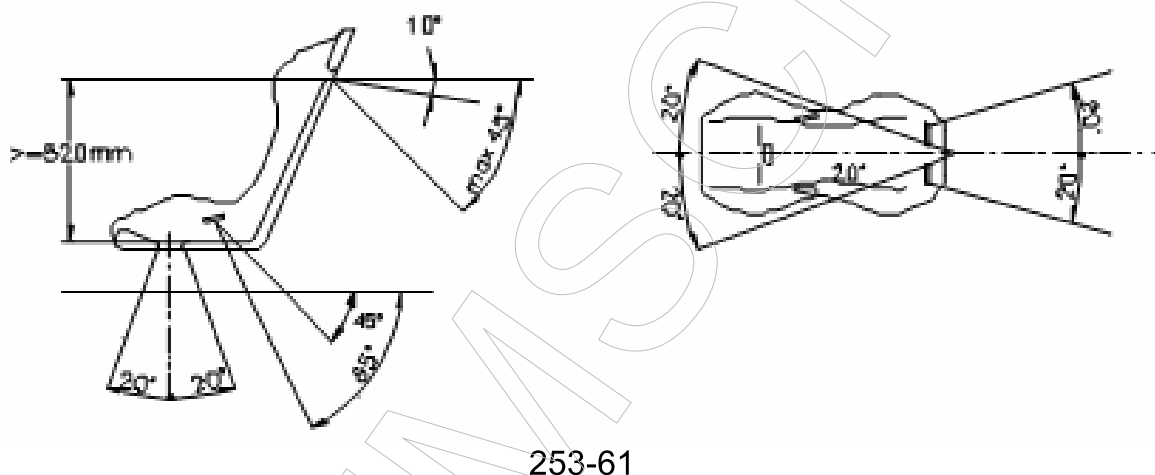

In the downwards direction, the shoulder straps must be directed towards the rear and must be installed in such a way that they do not make an angle of more than 45° to the horizontal from the upper rim of the backrest, although it is recommended that this angle should not exceed 10°.

The maximum angles in relation to the centre-line of the seat are 20° divergent or convergent. If possible, the anchorage point originally mounted by the car manufacturer on the C-pillar should be used.

Anchorage points creating a higher angle to the horizontal must not be used unless the seat meets the requirements of the FIA standard. In that case, the shoulder straps of 4-point safety harnesses may be installed on the rear seat lap strap anchorage points originally mounted by the car manufacturer.

For a 4 -point harness, the shoulder straps must be installed crosswise symmetrically about the centre-line of the front seat.

A safety harness must not be installed on a seat having no head restraint or having a backrest with integrated head restraint (no opening between backrest and head restraint).

The lap and crotch straps should pass not over the sides of the seat but through the seat, in order to wrap and hold the pelvic region over the greatest possible surface.

The lap straps must fit tightly in the bend between the pelvic crest and the upper thigh. Under no conditions must they be worn over the region of the abdomen.

Holes may be made in the series seat. Care must be taken that the straps cannot be damaged through chafing against sharp edges.

- If installation on the series anchorage points is impossible for the shoulder and/or crotch straps, new anchorage points must be installed on the shell or the chassis, as near as possible to the centre-line of the rear wheels for the shoulder straps.

The shoulder straps may also be fixed to the safety cage or to a reinforcement bar by means of a loop, and may also be fixed to the top anchorage points of the rear belts, or be fixed or leaning on a transversal reinforcement welded between the backstays of the cage (see Drawing 253-66).

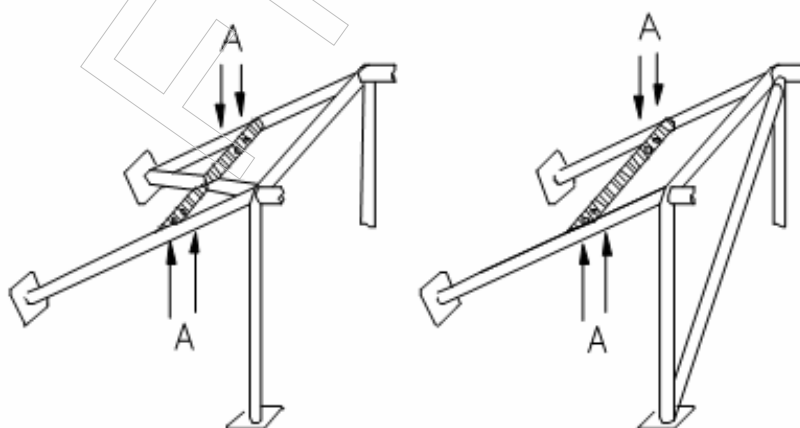

Ⓐ trous de montage pour harnais  
mounting holes for harness

253-66

In this case, the use of a transversal reinforcement is subject to the following conditions:

- The transversal reinforcement shall be a tube measuring at least 38 mm x 2.5 mm or 40 mm x 2 mm, made from cold drawn seamless carbon steel, with a minimum yield strength of 350 N/mm<sup>2</sup>.
- The height of this reinforcement must be such that the shoulder straps, towards the rear, are directed downward with an angle of between 10° and 45° to the horizontal from the rim of the backrest, an angle of 10° being recommended.
- The straps may be attached by looping or by screws, but in the latter case an insert must be welded for each mounting point (see Drawing 253-67 for the dimensions).

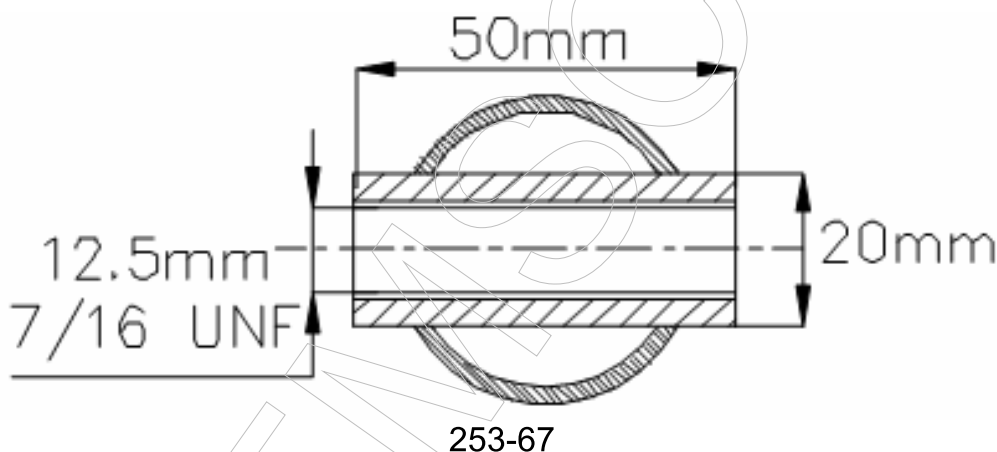

These inserts will be positioned in the reinforcement tube and the straps will be attached to them using bolts of M12 8.8 or 7/16UNF specification.

- Each anchorage point must be able to withstand a load of 1470 daN, or 720 daN for the crotch straps.

In the case of one anchorage point for two straps, the load considered will be equal to the sum of the required loads.

- For each new anchorage point created, a steel reinforcement plate with a surface area of at least 40 cm<sup>2</sup> and a thickness of at least 3 mm must be used.

- Principles of mounting to the chassis / monocoque:

1) General mounting system: see Drawing 253-62.

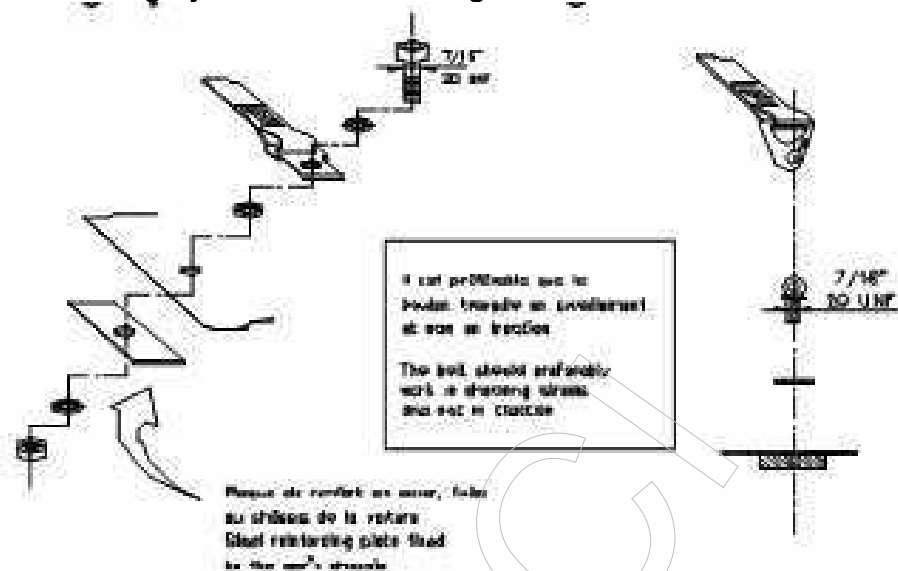

253-62

2) Shoulder strap mounting: see Drawing 253-63.

plaque fixée au châssis de la voiture et renforcée  
de l'autre côté par une plaque de renfort

plate fixed to the chassis and strengthened  
by a reinforced plate on the other side

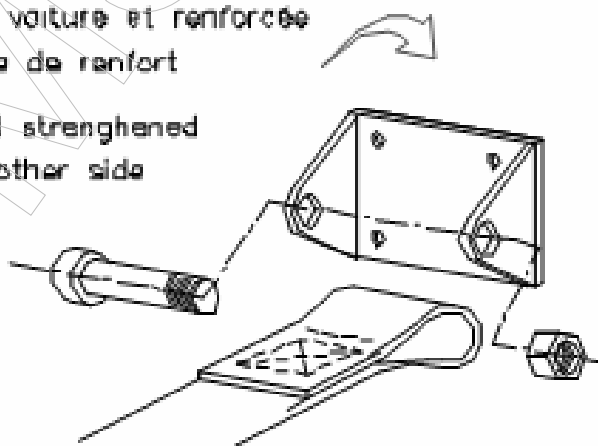

253-63

3) Crotch strap mounting: see Drawing 253-64.

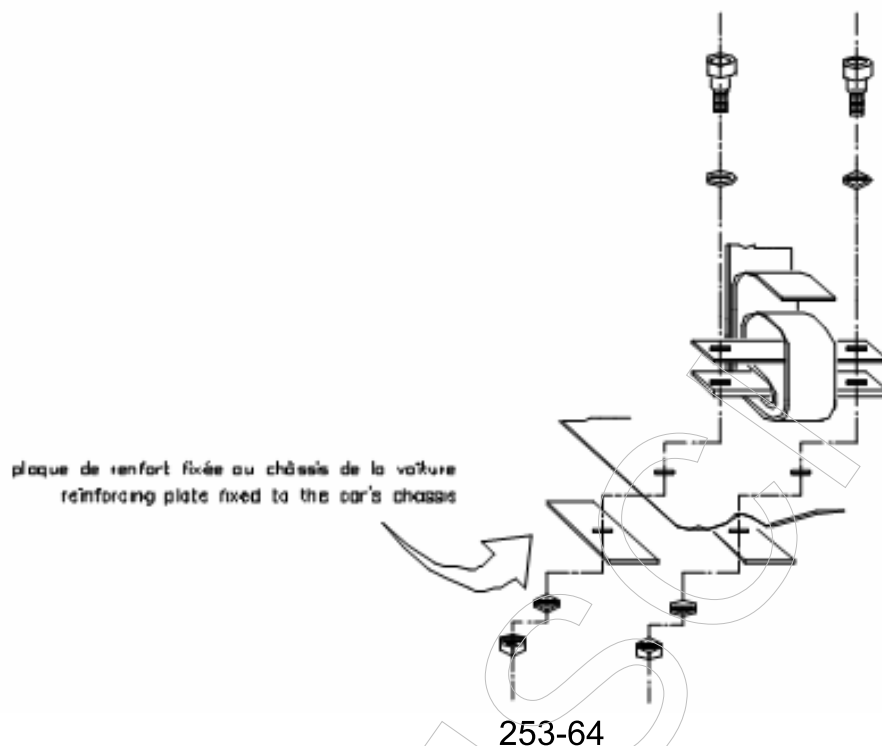

### 6.3 Use

A safety harness must be used in its homologation configuration without any modifications or removal of parts, and in conformity with the manufacturer's instructions.

The effectiveness and longevity of safety belts are directly related to the manner in which they are installed, used and maintained.

The belts must be replaced after every severe collision, and whenever the webbing is cut, frayed or weakened due to the actions of chemicals or sunlight. They must also be replaced if metal parts or buckles are bent, deformed or rusted.

Any harness which does not function perfectly must be replaced.

## ARTICLE 7 : EXTINGUISHERS – EXTINGUISHING SYSTEMS

The use of the following products is prohibited: BCF, NAF.

For FMSCI events all competing cars must be fitted with fire extinguishers having a minimum capacity as follows:

- a) Dry Powder - 2kg
- b) AFFF - 2.4kg
- c) Halon - 4kg. – 1211 or 1301

It is permitted to use multiple units so long as its total capacity conforms to the minimum capacity.

All extinguishers must be adequately protected.

Their mountings must be able to withstand a deceleration of 25 g.

Furthermore, only quick-release metal fastenings, with metal straps, will be accepted.

The extinguishers must be easily accessible for the driver and the co-driver.

The following information must be visible on each extinguisher:

- capacity
- type of extinguishant
- weight or volume of the extinguishant
- date the extinguisher must be checked, which must be no more than two years after either the date of filling or the date of the last check.

**7.1 XXX**

**7.2 XXX**

**7.2.1) XXX**

**7.2.2)** All extinguishers must be adequately protected and must be situated within the cockpit.

In all cases their mountings must be able to withstand a deceleration of 25 g.

All extinguishing equipment must withstand fire.

Plastic pipes are prohibited and metal pipes are obligatory.

**7.2.3)** The driver must be able to trigger all extinguishers manually when seated normally with his safety belts fastened and the steering wheel in place.

**7.2.4)** The system must work in all positions.

**7.2.5)** Extinguisher nozzles must be suitable for the extinguishant and be installed in such a way that they are not directly pointed at the occupants' heads.

### **7.3 Manual extinguishers**

**7.3.1)** All cars must be fitted with one or two fire extinguishers.

**7.3.2)** Permitted extinguishants: AFFF, FX G -TEC, Viro3, powder or any other extinguishant .

**7.3.3)** Minimum quantity of extinguishant:

AFFF: 2.4 litres

FX G-TEC: 2.0 kg

Viro3: 2.0 kg

Zero 360 2,0 kg

Powder: 2.0 kg

**7.3.4)** All extinguishers must be pressurised according to the contents:

AFFF: in accordance with the manufacturer's instructions FX G-TEC and

Viro3: in accordance with the manufacturer's instructions Zero 360: in accordance with the manufacturer's instructions

Powder: 8 bar minimum, 13.5 bar maximum

Furthermore, each extinguisher when filled with AFFF must be equipped with a means of checking the pressure of the contents.

**7.3.5)** XXX.

**7.3.6)** All extinguishers must be adequately protected. Their mountings must be able to withstand a deceleration of 25 g.

Furthermore, only quick-release metal fastenings (two minimum), with metal straps, will be accepted.

7.3.7) The extinguishers must be easily accessible for the driver and the co-driver.

## **ARTICLE 8 : SAFETY CAGES**

### **8.1 General :**

The fitting of a safety cage is compulsory.

It may be either :

- a) Fabricated in compliance with the requirements of the following articles ;
- b) Homologated or Certified by an ASN according to the homologation regulations for safety cages ;

### **ROLLOVER STRUCTURES**

Minimum rollcage specifications is as per drawing 253-3 of the FIA.

#### **8.1 Definitions**

##### **8.1.1) Safety cage:**

A structural framework designed to prevent serious bodyshell deformation in the case of a collision or of a car turning over.

##### **8.1.2) Rollbar:**

Structural frame or hoop and mounting points.

##### **8.1.3) Rollcage:**

Structural framework made up of a main rollbar and a front rollbar (or of two lateral rollbars), their connecting members, one diagonal member, backstays and mounting points. (For example, see drawings 253-3 and 253-4 of the FIA).

##### **8.1.4) Main rollbar:**

Structure consisting of a near-vertical frame or hoop located across the vehicle just behind the front seats.

**8.1.5) Front rollbar:**

Similar to main rollbar but its shape follows the windscreen pillars and top screen edge.

**8.1.6) Lateral rollbar:**

Structure consisting of a near-vertical frame or hoop located along the right or left side of the vehicle.

The rear legs of a lateral rollbar must be just behind the front seats. The front leg must be against the screen pillar and the door pillar such that it does not unduly impede the entry or exit of driver and co-driver.

**8.1.7) Longitudinal member:**

Longitudinal tube which is not a part of the main, front or lateral rollbar and linking them, together with the backstays.

**8.1.8) Diagonal member:**

Transverse tube between a top corner of the main rollbar or upper end of a backstay and a lower mounting point on the other side of the rollbar of backstay.

**8.1.9) Framework reinforcement:**

Reinforcing member fixed to the rollcage to improve its structural efficiency.

**8.1.10) Reinforcement plate:**

Metal plate fixed to the bodyshell or chassis structure under a rollbar mounting foot to spread load into the structure.

**8.1.11) Mounting foot:**

Plate welded to a rollbar tube to permit its bolting or welding to the bodyshell or chassis structure, usually onto a reinforcement plate.

**8.1.12) Removable members:**

Structural members of a safety cage which must be able to be removed.

## **8.2 Specifications**

### **8.2.1) General comments:**

**8.2.1.1)** Safety cage must be designed and made so that, when correctly installed, they substantially reduce bodyshell deformation and so reduce the risk of injury to occupants.

The essential features of safety cages are sound construction, designed to suit the particular vehicle, adequate mountings and a close fit to the bodyshell.

Tubes must not carry fluids.

The safety cage must not unduly impede the entry or exit of the driver and co-driver.

Members may intrude into the occupant's space in passing through the dashboard and front side-trim, as well as through the rear side-trim and rear seats.

### **8.2.1.2) Basic safety cage:**

Only rollcages must be used.

### **8.2.1.3) Compulsory diagonal member:**

Different ways of fitting the compulsory diagonal member: see drawings 253-3 to 253-5 of the FIA.

The combination of several members is permitted according to drawings 253-3 and 253-5 of the FIA.

The fitting of a second diagonal member, according to drawing 253-4 of the FIA, is recommended.

The connection between the two members must be reinforced by a gusset.

### **8.2.1.4) XXX**

### **8.2.2) Technical specifications:**

#### **8.2.2.1) Main, front and lateral rollbars:**

These frames or hoops must be made in one piece without joints.

Their construction must be smooth and even, without ripples or cracks.

The vertical part of the main rollbar must be as straight as possible and as close as possible to the interior contour of the bodyshell.

The front leg of a front rollbar or of a lateral rollbar must be straight, or if it is not possible, must follow the windscreen pillars and have only one bend with its lower vertical part.

To achieve an efficient mounting to the bodyshell, the original interior trim may be modified around the safety cages and their mountings by cutting it away or by distorting it.

However, this modification does not permit the removal of complete parts of upholstery or trim.

Where necessary, the fuse box may be moved to enable a rollcage to be fitted.

#### **8.2.2.2) Mounting of rollcages to the bodyshell:**

Minimum mountings are:

- 1 for each leg of the main or lateral rollbar ;
- 1 for each of the front rollbar ;
- 1 for each backstay

Each mounting foot of the front, main and lateral rollbars must include a reinforcement plate, of a thickness of at least 3 mm which must not be less than that of the tube onto which it is welded.

Each mounting foot must be attached by at least three bolts on a steel reinforcement plate at least 3 mm thick and of at least 120 cm<sup>2</sup> area which is welded to the bodyshell.

Bolts must be of at least M8 size of ISO standard 8.8 or better.

Fasteners must be self-locking or fitted with lock washers.

These are minimum requirements.

In addition to these requirements, more fasteners may be used, the rollbar legs may be welded to reinforcement plates, the rollcage may be welded to the bodyshell.

Rollbar mounting feet must not be welded directly to the bodyshell without a reinforcement plate.

#### **8.2.2.3) XXX**

#### **8.2.2.4) Diagonal members:**

At least one diagonal member must be fitted.

Their location must be in accordance with drawings 253-3 to 253-5 of the FIA and they must be straight, not curved.

The attachment points of the diagonal members must be so located that they cannot cause injuries.

They may be made removable but must be in place during events.

The lower end of the diagonal must join the main rollbar of backstay not further than 100 mm from the mounting foot.

The upper end must join the main rollbar not further than 100 mm from the junction of the backstay joint, or the backstay not more than 100 mm from its junction with the main rollbar.

They must comply with the minimum specification set out in 8.3.

#### **8.2.2.5) Optional reinforcement of the rollcage:**

The diameter, thickness and material of reinforcements must be as defined in 8.3.

They shall be either welded in position or installed by means of dismountable joints.

#### **8.2.2.5.1) Transverse reinforcing members:**

The fitting of two transverse members as shown in drawing 253- 7 of the FIA is permitted.

The transverse member fixed to the front rollbar must not encroach upon the space reserved for the occupants.

It must be placed as high as possible but its lower edge must not be higher than the top of the dashboard.

#### **8.2.2.5.2) Doorbars (for side protection):**

One or more longitudinal members may be fitted at each side of the vehicle (see drawings 253-7, 253-8, 253-12, 253-17 of the FIA ). They may be removable.

If these upper attachment points are located in front of or behind the door opening, this height limitation is also valid for the corresponding intersection of the strut and the door opening.

In the case of doorbars in the form of an "X" (cross-struts), it is recommended that the lower attachment points of the cross-struts be fixed directly onto the longitudinal member and that at least one part of the "X" be a single-piece bar.

#### **8.2.2.5.3) Roof reinforcement:**

Reinforcing the upper part of the rollcage by adding members as shown in drawings 253-9 and 253-9A is permitted.

#### **8.2.2.5.4) Reinforcement of bends and junctions:**

It is permitted to reinforce the junction of the main rollbar or the front rollbar with the longitudinal struts (drawings 253-10 and 253-16 of the FIA ), as well as the top rear bends of the lateral rollbars and the junction between the main rollbar and the backstays.

#### **8.2.2.6) Protective padding:**

Where the occupants' bodies or their crash helmets could come into contact with the safety cage, non-flammable padding must be provided for protection.

**8.2.2.7) Removable members:**

Should removable members be used in the construction of a rollcage, the dismountable joints used must comply with a type approved by the FIA (see drawings 253-27 to 253-37 of the FIA). They must not be welded.

The screws and bolts must be of ISO standard 8.8 or better.

**8.2.2.8) Guidance on welding :**

All welding must be of the highest possible quality with full penetration and preferably using a gas-shielded arc.

They must be carried out along the whole perimeter of the tube.

Although good external appearance of a weld does not necessarily guarantee its quality, poor looking welds are never a sign of good workmanship.

When using head-treated steel the special instructions of the manufacturers must be followed (special electrodes, gas protected welding).

It must be emphasised that the use of heat-treated or high carbon steels may cause problems and that bad fabrication may result in a decrease in strength (caused by brittle heat-affected zones), inadequate ductility and internal stress.

**8.3 Material specifications : Specifications of the tubes used:**

Material	Minimum tensile strength	Dimensions (mm) minimum	Use
Cold drawn seamless Unalloyed carbon steel (see below) Containing a maximum of 0.3 % of carbon	350 N/mm <sup>2</sup>	<b><u>45mm x 2.5mm</u></b> or <b><u>50mm x 2mm</u></b>	Main rollbar (drawing 253-39 of the FIA) Lateral rollbar and their connection (drawing 253-40 of the FIA) according to construction.
		38(1.5") x 2.5 or 40(1.6") x 2.0	Others parts of the safety cage

**8.4 DRAWING N- 253 — 17B IS HIGHLY RECOMMENDED FOR ALL ROLL CAGES**

8.5 XXX

8.6 XXX

**ARTICLE 9 : REAR VIEW**

Rearward visibility must be ensured by two rear-view mirrors. These rear-view mirrors may be as standard.

Each rear-view mirror must have a reflecting surface of at least 90 cm<sup>2</sup>.

An inside rear-view mirror is optional.

Application: Groups N.

Application: only in rallies, Groups N and N+.

**ARTICLE 10 : TOWING-EYE**

All cars will be equipped with a rear and front towing-eye for all events. This towing-eye will only be used if the car can move freely. It will be clearly visible and painted in yellow, red or orange.

**ARTICLE 11 : WINDOWS / NETS**

**Windows.**

The windows must be certified for road use, their marking standing as proof.

The windshield must be made of laminated glass.

A sun strip ( Maximum height 10 cm ) for the windscreen is authorised, on condition that it allows the occupants to see the road signs (traffic lights, traffic signs...).

The use of tinted glass (laminated glass) and/or safety film is permitted inside and rear windows. In such cases it must be possible for a person situated 5 m from the car to see the driver as well as the contents of the car.

The use of transparent and colourless anti-shatter films on the side windows and the glass sunroof is mandatory.

The thickness of these films must not be greater than 100microns.  
Application: Groups N and N+

A broken windshield / windows, must be replaced at the end of the leg(Art. 20.2)

If a car has to drive through a few stages to reach the end of the leg, the crew, will have to wear a pair of goggles and a full face helmet to complete the leg. This will apply if they reach a service before the end of the leg. The replacement of the windshield is not required at the end of the rally.

#### **ARTICLE 12 : SAFETY FIXING DEVICES FOR WINDSHIELD**

Such devices may be used freely.

Application: Groups N and N+

#### **ARTICLE 13 : GENERAL CIRCUIT BREAKER**

The general circuit breaker must cut all electrical circuits, battery, alternator or dynamo, lights, hooters, ignition, electrical controls, etc.) and must also stop the engine.

It must be a spark-proof model, and will be accessible from inside and outside the car.

#### **ARTICLE 14 : FIA APPROVED SAFETY FUEL TANKS**

Whenever a competitor uses a safety fuel tank, it must come from a manufacturer approved by the FIA.

In order to obtain the FIA's agreement, a manufacturer must have proved the constant quality of its product and its compliance with the specifications approved by the FIA.

Safety tank manufacturers recognised by the FIA must undertake to deliver to their customers exclusively tanks complying with the norms approved.

To this end, on each tank delivered the name of the manufacturer, the exact specifications according to which this tank has been manufactured, the homologation date the date of the end of validity, and the series number, shall be marked.

The marking process must be indelible and must have been approved beforehand by the FIA according to the prevailing standard.

#### **14.1 Technical specifications**

The FIA reserves the right to approve any other set of technical specifications after study of the dossier submitted by the manufacturers concerned.

#### **14.2 Specifications FT3 1999, FT3.5 or FT5**

The technical specifications for these tanks are available, on request, from the FIA Secretariat.

#### **14.3 Ageing of tanks**

The ageing of safety tanks entails a considerable reduction in the strength characteristics after approximately five years.

No bladder shall be used more than 5 years after the date of manufacture, unless inspected and recertified by the manufacturer for a period of up to another two years.

#### **14.4 Applications of these specifications**

Group N, Group A and Group B cars may be equipped with an FT3 1999, FT3.5 or FT5 safety fuel tank if the modifications necessary do not exceed those allowed by the regulations.

The use of safety foam in FT3 1999, FT3.5 or FT5 tanks is recommended.

#### **14.5 Fuel tanks with filler necks, Groups A and N**

All cars fitted with a fuel tank with filler neck passing through the cockpit must be equipped with a non-return valve homologated by the FIA. This valve, of the type “with one or two flaps”, must be installed in the filler neck on the tank side.

The filler neck is defined as being the means used to connect the fuel filler hole of the vehicle to the fuel tank itself.

#### **ARTICLE 15 : PROTECTION AGAINST FIRE**

An efficient protective screen must be placed between the engine and the occupant's seat, in order to prevent the direct passage of flames in case of fire.

Should this screen be formed by the rear seats, it is advisable to cover them with a flameproof coating.

#### **ARTICLE 16 : SEATS, ATTACHMENTS AND SUPPORTS**

If the original seat attachments or supports are changed, the new parts must either be approved for that application by the seat manufacturer or must comply with the following specifications (see Drawing 253-65) :

- 1) Supports must be attached to the shell/chassis via at least 4 mounting points per seat using bolts with a minimum diameter of 8 mm and counterplates.
- 2) The minimum area of contact between support, shell/chassis and counterplate is 40 cm<sup>2</sup> for each mounting point.

If quick release systems are used, they must be capable of withstanding vertical and horizontal forces of 18000 N, applied non-simultaneously. If rails for adjusting the seat are used, they must be those originally supplied with the homologated car or with the seat.

- 3) The seat must be attached to the supports via 4 mounting points, 2 at the front and 2 at the rear of the seat, using bolts with a minimum diameter of 8 mm and reinforcements integrated into the seat.

#### **ARTICLE 17 : PRESSURE CONTROL VALVES**

Pressure control valves on the wheels are forbidden.

**\*\* END \*\***

## **Specific Regulations for Production Cars IV – Group N**

*With effect from 1st January 2009*

### **ARTICLE 1 : DEFINITION**

Large scale series production touring cars.

### **ARTICLE 2 : HOMOLOGATION**

At least 2500 identical units must have been produced in 12 consecutive months and homologated by the FMSCI in Touring Cars (Group A).

The Supply Variants (VF) homologated in Touring Cars (Group A) are also valid in Production Cars (Group N).

All Production Variants (VP) are valid in Production Cars (Group N). Option Variants (VO) of the Touring Cars (Group A) form shall not be valid in Production Cars (Group N), unless they refer to:

- engine flywheel of the same diameter and the same weight as the original, if and only if this original flywheel is made up of two parts.
- fly-wheel for automatic gearboxes ;
- fuel tank ;
- automatic gearboxes ;
- sun roof (includes the roof vents with a flap);
- safety cage ;
- seat supports and anchorages;
- safety harness mounting points;
- 2/4 doors versions.

### **ARTICLE 3 : NUMBER OF SEATS**

Seats With Head Rests Are Mandatory

- FIA Homologated Seats Are RECOMMENDED
- OE SEATS ARE NOT PERMITTED

THE TECHNICAL DELEGATE IS THE FINAL AUTHORITY ON THE CONDITION AND SAFETY OF THE SEATS USED

**ARTICLE 4 : MODIFICATIONS AND ADJUNCTIONS ALLOWED OR OBLIGATORY**

All the modifications which are not allowed by the present regulations are expressly forbidden.

The only work which may be carried out on the car is that necessary for its normal servicing, or for the replacements of parts worn through use or accident.

The limits of the modifications and fittings allowed are specified hereinafter. Apart from these, any part worn through use or accident can only be replaced by an original part identical to the damaged one. *Blue printing of engines is not permitted. However it is permitted to machine the following parts.*

- 1) It is permitted to machine the gasket plane of the cylinder block, so long as Article 311 and Article 317 of the homologation form is respected.
- 2) It is permitted to machine the gasket plane of cylinder head, so long as Article 309 of the homologation form is respected. The finish of the combustion chamber should be as supplied by the manufacturer.

The cars must be strictly series production models identifiable by the homologation form data.

**ARTICLE 5 : MINIMUM WEIGHT**

**5.1 Cars must have at least the weight appearing on the homologation form.**

This is the real weight of the empty car (without persons or luggage aboard) without tools or jack, and with a maximum of one spare wheel. When two spare wheels are carried in the car, the second spare wheel must be removed before weighing. All the liquid tanks (lubrication, cooling, braking, heating where applicable) must be at the normal level foreseen by the manufacturer, with the exception of the windscreen wiper or headlight wiper, brake cooling system, fuel and water injection tanks, which shall be empty.

Additional headlights which do not appear on the homologation form must be removed before weighing.

As far as rollcages which cannot be removed from the car, and which were manufactured in accordance with FMSCI Technical Regulations Group N – III Articles 8.2 and 8.3, are concerned, the following weights will be taken as a basis:

- Rollcage according to drawings 253-3/4: 30 kg
- Rollcage according to drawings 253-5 to 17C: 35 kg

## **ARTICLE 6**

### **6.1 Engine**

- Engine shields made of plastic material, the purpose of which is to hide mechanical components in the engine compartment, may be removed if they have a solely aesthetic function.
- Soundproofing material and trim fitted under the bonnet and not visible from the outside may be removed.
- The accelerator cable may be replaced or doubled by another one regardless of whether it comes from the manufacturer or not. This replacement cable must be an emergency cable, i.e. it must be fitted in parallel with the series accelerator cable. If the series vehicle is fitted with a motorised throttle valve, a throttle kit with a mechanical linkage, homologated in Group N, may be used.
- The screws and bolts may be changed, provided that the replacements are made from ferrous material.
- Ignition: The make and type of the spark plugs, rev. limiter and hightension leads are free.

The electronic control unit and the ignition components in the electronic control unit are free, **NEVERTHELESS THE SYSTEM MUST BE MECHANICALLY INTERCHANGEABLE WITH THE ORIGINAL UNIT.**

The original loom must be kept and cannot be modified. Sensors and actuators on the input side must be standard, as must their function.

No sensor may be added, even for the purpose of data recording. **IT IS PROHIBITED TO ADD A SWITCH IN THE ORIGINAL WIRING LOOM BETWEEN THE ELECTRONIC CONTROL UNIT AND A SENSOR AND/OR ACTUATOR.**

In the case of a model fitted with a multiplexed electric circuit, the use of a loom together with an electronic control unit homologated in Option Variant is permitted.

- Any data recording system is forbidden unless fitted on the homologated vehicle.

ONLY THE DATA LOGGING SYSTEM FITTED TO THE SERIES CAR MAY BE USED. IN NO CASE MAY IT BE MODIFIED OR RECORD ADDITIONAL PARAMETERS.

*Only the following sensors are authorised:*

*Water temperature, oil temperature, oil pressure and engine speed.*

*Each of these sensors may only be linked to one or several visual display units (with data recording capability) by means of a harness that is completely independent of any other harness*

- **Cooling system:** The thermostat is free as is the control system and the temperature at which the fan cuts in. Locking system for the radiator cap is free.

- **Carburettors:** The original system must be retained. The components of the carburettor which control the quantity of petrol entering the combustion chamber may be modified, provided that they do not have any influence over the quantity of air admitted.

Air Filters – FREE (Air Filtration methods are free upto the carburettor or the throttle body).

- **Injection:** The original system must be retained. Components of the injection system situated downstream of the air-flow measuring device, and which control the quantity of petrol entering the combustion chamber may be modified but not replaced, provided that they do not have any influence over the quantity of air admitted. The electronic control unit for the injection is free.

Inputs to the electronic control unit (sensors, actuators, etc.), including their function, must remain as standard.

IT IS PROHIBITED TO ADD A SWITCH IN THE ORIGINAL WIRING LOOM BETWEEN THE ELECTRONIC CONTROL UNIT AND A SENSOR AND/OR ACTUATOR.

Outputs from the electronic control unit must retain their original functions in accordance with the homologation form. In the case of a model fitted with a

multiplexed electric circuit, the use of a loom together with an electronic control unit homologated in Option Variant is permitted.

It is necessary to be certain that the sensors used by a vehicle fitted with a multiplexed electric circuit can be retained with the homologated loom.

The injectors may be modified or replaced in order to modify their flow rate, but without modifying their operating principle and their mountings. The injector rail may be replaced with another of free design but fitted with threaded connectors for connecting the lines and the fuel pressure regulator, provided that the mounting of the injectors is identical to the original.

Air Filters – FREE (Air Filtration methods are free upto the carburettor or the throttle body).

The resonator unit located within the mudguard, only, may be removed. If removed, the original opening in the apron may be closed

- **Lubrication:** The fitting of baffles in the oil sump is authorised. Replacement oil filter cartridges are accepted in the same way as the original ones.

- **Mountings:** The engine mountings ARE FREE , BUT NOT THEIR LOCATION AND NUMBER.

- **Exhaust** - FREE. (Exhaust manifold to the exit is free.) However the exhaust ports in the cylinder head should remain as provided by the manufacturer.

- The noise levels on the open road must not exceed 103dB(A) for an engine rotation speed of 3500 rpm for petrol engines and 2500 rpm for diesel engines

- The location of the exit of the exhaust pipe is free
- The exhaust system must not be provisional
- Exhaust gases may only exit at the end of the system

These liberties must not entail any bodywork modifications and must respect the laws of the country, with regard to noise levels.

- **Cylinder head gasket:**

The material is free, but not the thickness and dimensions.

---

**- Cruising speed controller:**

This controller may be disconnected.

**6.2 Transmission**

**6.2.1) Clutch:**

The disc is free, including the weight, with the exception of the number. The diameter of the clutch disc may be increased.

**6.2.2) Gearbox:**

The interior of the gearbox is free. Any ratio homologated by the FMSCI in Group N may be used. The joints of the gearbox linkage are free. The gear selection grid pattern homologated on the series model must be retained.

The Gear – box mountings are free, but not their location and number.

THE GEAR BOX RATIOS AND THE FINAL DRIVE RATIOS OF THE MARUTI ESTEEM, MAY BE INTERCHANGED WITH THE OTHER HOMOLOGATED RATIOS OF MARUTI CARS eg MARUTI ZEN / MARUTI 1000 etc

**6.2.3) Differential:**

Four Pinion differential case is permitted, so long as it can be fitted in the series housing.

The use of a mechanical type limited slip differential is authorised, provided that it can be fitted in the series housing and is homologated in Option Variant (VO).

"Mechanical limited slip differential" means any system which works purely mechanically, i.e. without the help of a hydraulic or electric system.

A viscous clutch is not considered to be a mechanical system. If the homologated vehicle is fitted with a viscous clutch, it may be retained but it will not be possible to add another differential.

Welding or locking of the differential pin ( spider pin ) to the differential is permitted.

#### **6.2.4) Half-shafts :**

They must be original or homologated in Option Variant (VO).

### **6.3 Suspension**

The modification of spring and shock absorber adjustments from the cockpit is prohibited.

The reinforcing of the structural parts of the suspension (with the exception of anti-roll bars) and its anchorage points by the addition of material is allowed. The suspension reinforcements must not create hollow sections and must not allow two separate parts to be joined together to form one.

#### **- Springs:**

The spring seats may be adjustable if the adjustable structural part is a part of the spring seat and is separated from the original suspension parts/bodywork (it may be removed).

#### **Coil springs:**

The length is free, as are the number of coils, the wire diameter, the external diameter, the type of spring (progressive or not) and the shape of the spring seats.

The number of springs and spring seats is free provided the springs are mounted in series.

#### **Leaf springs:**

The length, width, thickness and vertical curvature are free.

#### **Torsion bars:**

The diameter is free. These freedoms on the suspension springs do not authorise one to disregard article 205 of the homologation form (minimum height of the centre of the hubcap, wheel passage opening).

**- Shock absorbers:**

Free, provided that their number, their type (telescopic, arm, etc.), their working principle (hydraulic, friction, mixed, etc.), and their attachment points remain unchanged.

The checking of the operating principle of the shock absorbers will be carried out as follows :

Once the springs and/or the torsion bars are removed, the vehicle must sink down to the bump stops in less than 5 minutes.

The damper tanks may be attached onto the unmodified shell of the cars.

If the shock absorbers have separate fluid reserves located in the cockpit, or in the boot if this is not separated from the cockpit, these must be strongly fixed and must have a protection.

A silent block may be replaced by a "Uniball" joint, but only on condition that its position is same as the original. (Shock absorber top mounting)

Gas filled dampers, regarding their working principle, will be considered as hydraulic dampers.

**- Mc Pherson type suspension damper**

If, in order to change the damping element of a Mac Pherson suspension, or a suspension operating in an identical manner, it is necessary to replace the telescopic part and/or the shock strut (damper and system of connection to the hub carrier), the replacement parts must be mechanically equivalent to the original ones and have the same mounting points.

For McPherson suspensions, the shape of the spring seats is free. Their material is free.

In the case of oil-pneumatic suspension, the spheres may be changed as regards their dimension, shape and material, but not their number. A tap, adjustable from outside of the car, may be fitted on the spheres.

**- Silent blocks:**

The elastomer of a silent block may only be replaced with an elastomer (maximum hardness 80 Shores).

## 6.4 Wheels and tyres

### 6.4.1) Wheels:

The wheels are free, respecting the homologated maximum diameter (article 801.a), and maximum width (article 801.b). The use of wheels with lesser dimensions is permitted. **Wheel size 1J more than the homologated size will be permitted. Alloys wheels are permitted.** Wheels made from forged magnesium are forbidden (including standard wheels). They must be covered by the wings (same checking system as in Group A, article 255-5.4), and the maximum track given on the homologation form must be respected. Wheels fixations by bolts may be changed to fixations by pins and nuts provided that the number of attachment points and the diameter of the threaded parts as indicated on Drawing 254-1 are respected.

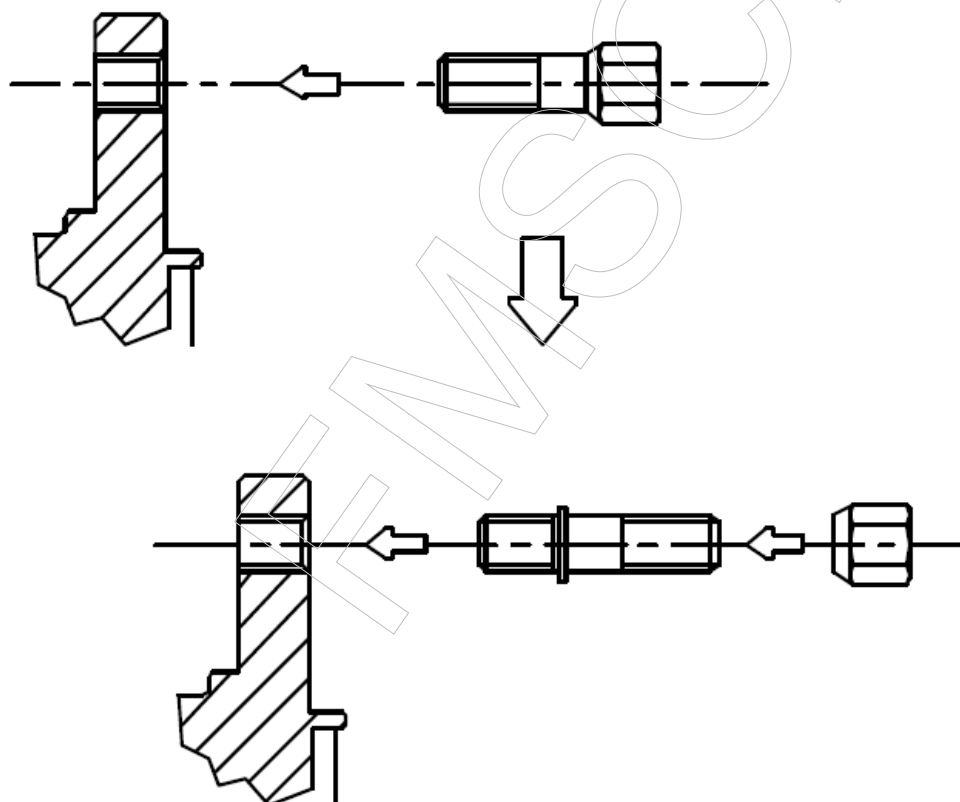

**254-1**

The wheel nuts may be changed, provided that their material remains ferrous. Air extractors added on the wheels are forbidden.

#### **6.4.2) Tyres:**

TYRES ARE FREE provided that they can be mounted on those wheels. The use of any device for maintaining the performance of the tyre with an internal pressure equal to or less than the atmospheric pressure is forbidden. The interior of the tyre (space between the rim and internal part of the tyre) must be filled only with air.

#### **6.4.3) Spare wheel:**

The spare wheel (wheels) is (are) compulsory if mentioned in the homologation form.

The spare wheel may be brought inside the driving compartment, on condition that it is firmly secured there and that it is not installed in the space reserved for the occupants.

#### **6.5 Braking system**

With the exception of the modifications authorised by this article, the braking system must be original or homologated in Option Variant (VO).

The electronic control unit of the braking system is free, but must be entirely interchangeable with the original unit (i.e. the braking system must work when the unit is replaced with the series unit). Sensors and actuators on the input side must be standard, as must their function.

No sensor may be added, even for the purpose of data recording. The electrical harness must not be modified. Brake linings are free, as well as their mountings (riveted, bonded, etc.) provided that the contact surface of the brakes is not increased. Protection plates may be removed or bent. In the case of a car fitted with servo-assisted brakes, this device may be disconnected or replaced with the kit homologated in Option Variant (VO). The same applies for anti-lock braking systems. If the anti-lock braking system (ABS) is disconnected or removed, the use of a mechanical rear braking distributor homologated by the manufacturer in VO is authorised.

It is permitted to add a spring in the bore of the calipers and to replace the seals and the dust covers of the callipers.

Brake lines may be changed for aviation type lines.

A device for scraping away the mud which collects on the brake discs and / or the wheels may be added.

6.5.1) **Handbrake:** The handbrake locking mechanism may be removed in order to obtain instant unlocking (fly-off handbrake). The mechanical handbrake may be replaced with a hydraulic system homologated in Group N, but in this case a diagonal brake circuit (X shape) or the original system is mandatory.

## 6.6 Steering

The lines linking the power steering pump to the rack may be replaced with lines conforming to article 253-3.2.

## 6.7 Bodywork

### 6.7.1) Exterior :

Hubcaps must be removed.

Protective headlight covers may be fitted provided that their only function is to cover the glass, and that they have no influence on the car's aerodynamics.

The fitting of underbody protections is authorised in rallies only, provided that these really are protections which respect the ground clearance, which are removable and which are designed exclusively and specifically in order to protect the following parts: engine, radiator, suspension, gearbox, tank, transmission, steering, exhaust, extinguisher bottles.

Underbody protections may extend the whole width of the underside part of the front bumper only in front of the front wheel axis.

The mountings of the front and rear bumpers cannot be modified (no additional mounting is authorised).

Any locking system may be used for the cap of the petrol tank.

The changing of the front and rear windscreen wiper blades is authorised.

Plastic sound-proofing parts may be removed from the wheel openings. These plastic elements may be changed for aluminium or plastic elements of

the same shape. Plastic protection parts fitted under the body (licked by the air flow) may be removed.

#### **6.7.2) Interior :**

The front seats may be moved backwards but not beyond the vertical plane defined by the front edge of the original rear seat. The limit relating to the front seat is formed by the height of the seat without the headrest, and if the headrest is incorporated into the seat, by the rearmost point of the driver's shoulders.

The rear seats may be removed.  
The rear safety belts may be removed.

**6.7.2.1)** Should the fuel tank be installed in the boot and the rear seats removed, a fireproof and liquid-proof bulkhead must separate the cockpit from the fuel tank.

In the case of twin-volume cars it will be possible to use a non-structural partition wall in transparent, non-flammable plastic between the cockpit and the tank arrangement.

#### **6.7.2.2) Dashboard:**

The dashboard and the central console must remain original.

#### **6.7.2.3) Doors - Side trim:**

It is permitted to remove the soundproofing material from the doors, provided that this does not modify the shape of the doors.

It is permitted to remove the original trim (door pads) from the doors provided a fabricated trim is installed in its place.

It is permitted to replace manual winders with electric ones.

#### **6.7.2.4) Floor :**

Carpets are free and may thus be removed.

**6.7.2.5) Other sound-proofing materials and trim:**

Other soundproofing materials and trim, except for those mentioned under Articles 6.7.2.3 (Doors) and 6.7.2.2 (Dashboard), may be removed.

**6.7.2.6) Heating system:**

The original heating equipment must be retained. The following parts of the air conditioning system may be removed:

condenser and auxiliary fan, fluid tank, evaporator and fan, expansion valve, as well as all pipes, connections, contact switches, sensors and actuators necessary for the functioning of the system. The compressor may be rendered inoperative.

**6.7.2.7)** The removable rear shelf in twin-volume cars may be removed.

**6.7.3) Additional accessories:**

All those which have no influence on the car's behaviour, for example equipment which improves the aesthetics or comfort of the car interior (lighting, heating, radio, etc.), are allowed without restriction.

In no case may these accessories increase the engine power or influence the steering, transmission, brakes, or roadholding, even in an indirect fashion.

All controls must retain the role laid down for them by the manufacturer. They may be adapted to facilitate their use and accessibility, for example a longer handbrake lever, an additional flange on the brake pedal, etc.

The following is allowed:

1) Measuring instruments such as speedometers etc. may be installed or replaced, and possibly have different functions. Such installations must not involve any risk. However, the speedometer may not be removed if the supplementary regulations of the event prevent this.

2) The horn may be changed and/or an additional one added, within reach of the passenger.

The horn is not compulsory on closed roads.

3) The handbrake locking mechanism may be removed in order to obtain instant unlocking (fly-off handbrake).

4) The steering wheel is free. The locking system of the anti-theft steering lock may be rendered inoperative. The release must be operated by pulling the flange along the steering wheel axis.

5) Additional compartments may be added to the glove compartment and additional pockets in the doors, provided that they use the original panels.

6) Insulating material may be added to protect the passengers or parts from fire or heating.

#### **6.7.4) Reinforcements :**

Reinforcement bars may be fitted on the suspension mounting points to the bodyshell or chassis of the same axle, on each side of the car's longitudinal axis, on condition that they are removable and are attached by means of bolts.

The distance between a suspension attachment point and an anchorage point of the bar cannot be more than 100 mm, unless the bar is a transversal strut homologated with the safety cage, or unless it is an upper bar attached to a MacPherson suspension or similar. In the latter case, the maximum distance between an anchorage point of the bar and the upper articulation point will be 150 mm (Drawings 255-2 and 255-4). Apart from these points, this bar must not be mounted on the bodyshell or the mechanical parts.

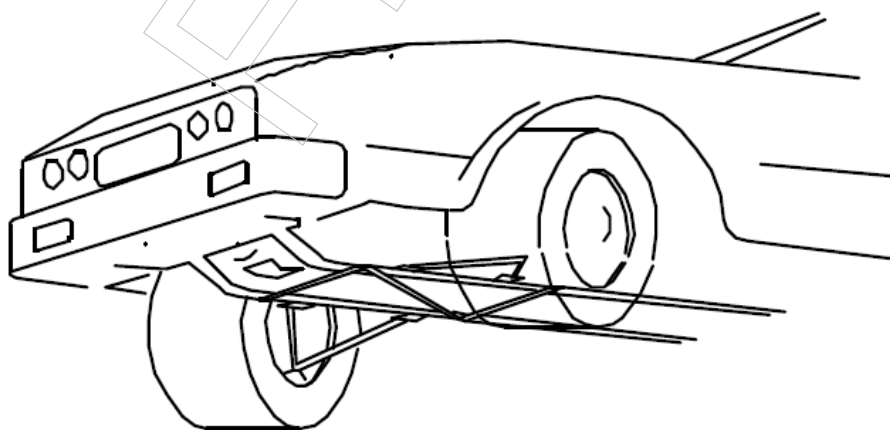

**255-2**

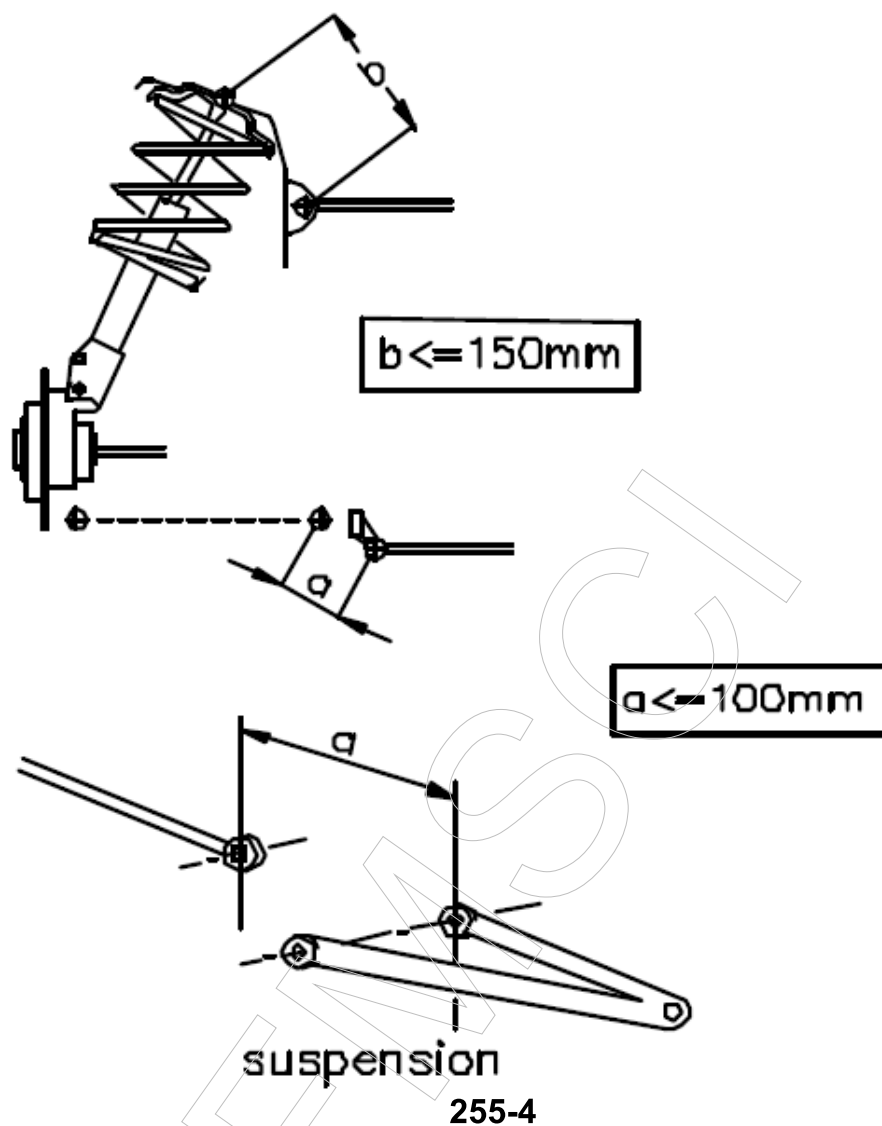

If the series vehicle is equipped with a reinforcement bar, it is permitted to remove or replace the series bar with a bar conforming to the prescriptions mentioned above.

Strengthening of the suspended part is allowed provided that the material used follows the original shape and is in contact with it.

**6.7.5)** When the spare wheel is originally set in a closed accommodation, and when this wheel is changed for a thicker one (see article 6.4), situated in this space, it is possible to remove from the cover of the location of the wheel the surface induced by the diameter of the new wheel (Drawing 254-2).

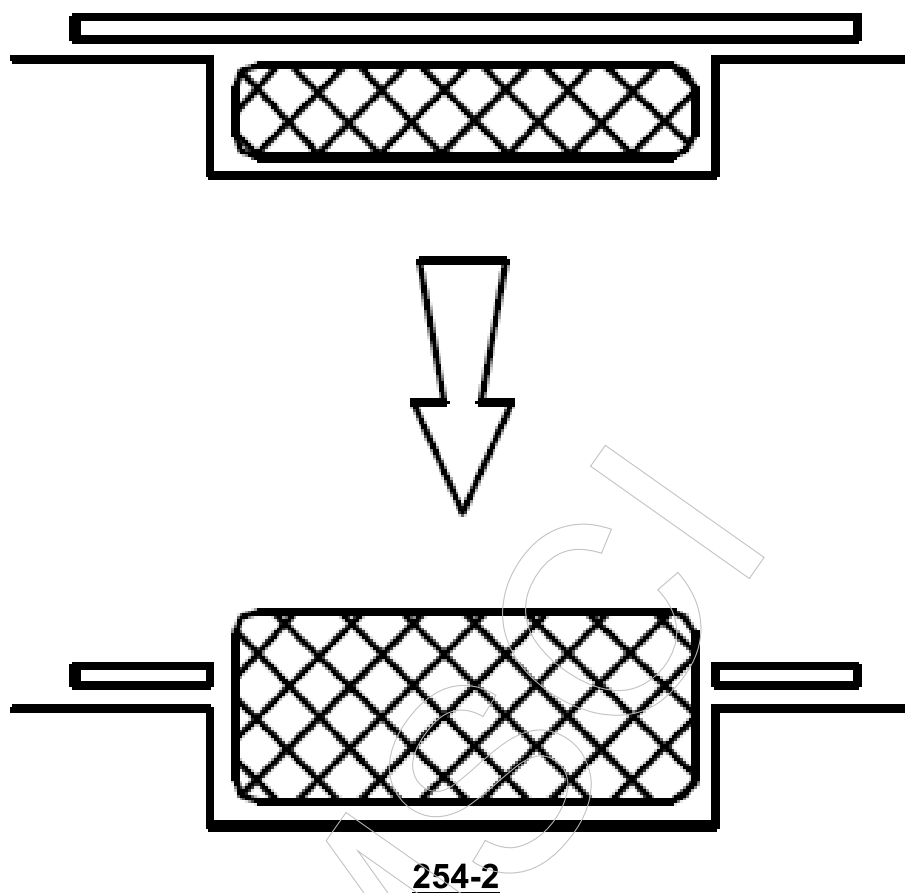

## 6.8 Electrical system

### - Battery:

The make, capacity, and battery cables are free.

The tension and the site of the battery may be changed

A power take-off connected to the battery is permitted in the passenger space.

### - Generator:

May be replaced by a more powerful one.

A dynamo may not be replaced by an alternator and vice-versa.

### - Lighting system:

Additional headlights including the corresponding relays are allowed, provided that the total does not exceed eight (tail and parking lights not included) and that this is accepted by the laws of the country.

They may not be housed within the bodywork.

Headlights and other exterior lights must always exist in pairs.

The original headlights can be made inoperative and covered with adhesive tape.

They can be replaced by other headlights, in compliance with this article.

A reversing light may be fitted provided it can only be used when the gear lever is in the "reverse" position, and provided that the police regulations on this subject are observed.

Fuses may be added to the electrical system.

### **6.9 Fuel circuit**

Providing the original tank is equipped with an electric pump and an interior filter, it is possible when using an FT3 1999, FT3.5 or FT5 tank or another tank homologated by the manufacturer on the car's homologation form to place a filter and a pump with identical characteristics to the homologated one outside. These parts must be protected in adequate fashion

The fitting of a second fuel pump is authorised, but this must be only a spare fuel pump, i.e. it cannot operate in addition to the authorised pump. It must be connectable only when the car is immobile and by means of a purely mechanical device situated beside the pumps.

The filler holes may not be located in the window panels. Fuel lines must be changed for aviation type lines if an FT3 1999, FT3.5 or FT5 tank is used, the route of these lines being free.

Should a series production tank be used, this change is optional. The total capacity of the tanks must not exceed that indicated in article 401.d of the Group N homologation form, except for rallies, if the car is fitted with FT3 1999, FT3.5 or FT5 tanks. In this case, the total capacity of the tanks must not exceed the following limits, in relation to the engine capacity:

up to 700 cm<sup>3</sup>: 60 l  
over 700 cm<sup>3</sup> and up to 1000 cm<sup>3</sup>: 70 l  
over 1000 cm<sup>3</sup> and up to 1400 cm<sup>3</sup>: 80 l  
over 1400 cm<sup>3</sup>: 95 l

For twin-volume cars homologated from 01.01.98 with a fuel tank installed in the luggage compartment, a fireproof and liquid-proof case must surround the fuel tank and its filler holes.

For three-volume cars homologated from 01.01.98, a fireproof and liquid-proof bulkhead must separate the cockpit from the fuel tank.

Nevertheless, it is recommended that this liquid-proof bulkhead be replaced by a liquid-proof case as for twin-volume cars.

### **6.10 Jack**

The jacking points may be strengthened, moved and increased in number. These modifications are limited exclusively to the jacking points.

The cage of any car with a corrected cylinder capacity greater than 2000 cm<sup>3</sup>, homologated after 01/01/2006 must be homologated or certified by an ASN, or homologated by the FIA.

<b>ARTICLE 7: CARS WITH A CORRECTED CYLINDER CAPACITY GREATER THAN 2L</b>
---

The following articles apply only to cars with a corrected cylinder capacity greater than 2L.

### **7.1 Engine**

#### **7.1.1) Engine flywheel**

It will be possible to use an engine flywheel homologated as a Group N Option Variant.

#### **7.1.2) Cooling system**

It will be possible to use lines homologated as a Group N Option Variant.

#### **7.1.3) Data logging**

A data logging system is authorised, even if the series vehicle is not so equipped.

It must be connected only:

- to the series sensors
- to the following sensors which it will be possible to add: water temperature, oil temperature, oil pressure and engine speed.

Any exchange of data with the car by a method other than cable link or chip card is prohibited.

#### **7.1.4) Anti-lag system**

A switch and an electric loom may be added for the sole purpose of activating the anti-lag system.

### **7.2 Transmission**

#### **7.2.1) Clutch**

It will be possible to use the clutch mechanism pressure plate as well as the controls homologated as a Group N Option Variant.

#### **7.2.2) Gearbox control**

It will be possible to use the control homologated as a Group N Option Variant.

#### **7.2.3) Front and rear differentials**

Only mechanical type limited-slip differentials with plates are authorised.

Mechanical type limited-slip differentials with plates must:

- either come from the series model
- or be homologated as a Group N Option Variant.

A mechanical limited-slip differential is any system that works exclusively mechanically, that is, without the assistance of a hydraulic or electric system.

A viscous clutch is not considered as a mechanical system.

Any differential with electronic management is prohibited.

The number and the type of the plates are free.

#### **7.2.4) Lubrification**

An additional lubrication and oil cooling device is allowed provided it is homologated in Option-Variant (VO).

## 7.3 Suspension

### 7.3.1) Upper suspension plate

It will be possible to use upper suspension plates homologated as a Group N Option Variant.

### 7.3.2) Anti-roll bars

It will be possible to use anti-roll bar diameters homologated as a Group N Option Variant.

## 7.4 Brakes

### 7.4.1) Brake discs

It will be possible to use brake discs homologated as a Group N Option Variant.

### 7.4.2) Brake callipers

It will be possible to use brake callipers homologated as a Group N Option Variant.

## 7.5 Wheels and Tyres

Complete wheels (as well as tracks) are free, provided that they can be housed within the original bodywork; this means that the upper part of the complete wheel, located vertically over the wheel hub centre, must be covered by the bodywork when measured vertically.

Wheel fixations by bolts may be freely changed to fixations by pins and nuts.

The use of tyres intended for motorcycles is forbidden.

Rims must imperatively be made from aluminium **alloy or steel**.

\* For gravel rallies, the maximum dimension of the rims is 7" x 15".

\* If specified in the Supplementary Regulations of the event (such as snow rallies), the maximum dimension of the rims is 5" x 16" **5.5" x 16"**.

\* For asphalt rallies, the maximum dimension of the rims is 8" x 18".

Air extractors added on to the wheels are prohibited.

### **Specific Regulations for Maruti Esteem**

1. MPFI Engines may be installed into Type I cars. The car should comply with the MPFI homologation form, irrespective of model and year of manufacture example – if a Type I Maruti Esteem is fitted with an MPFI engine, the car in totality should comply with the MPFI homologation form (including the body shell components)

It means that any car presented for pre-event scrutiny, must comply with a homologation form in totality.

**\*\* END \*\***

FMSCI

**2008 Technical Regulations (1601cc upto 2000 cc)  
Group N+ Specific Regulations**

*With effect from January 2009*

**ARTICLE 1 : DEFINITION**

Large scale series production touring cars.

**ARTICLE 2: HOMOLOGATION**

At least 2500 identical units must have been produced in 12 consecutive months and Homologated by the MAI in Touring Cars (Group A).

**ARTICLE 3: SEATS**

Seats With Head Rests Are Mandatory

- FIA Homologated Seats Are Mandatory

THE TECHNICAL DELEGATE IS THE FINAL AUTHORITY ON THE  
CONDITION AND SAFETY OF THE SEATS USED

**ARTICLE 4: MODIFICATIONS AND ADJUNCTIONS ALLOWED OR  
OBLIGATORY**

All the modifications that are not allowed by the present regulations are expressly forbidden.

The only work which may be carried out on the car is that necessary for its normal servicing, or for the replacements of parts worn through use or accident. The limits of the modifications and fittings allowed are specified hereinafter.

Apart from these, any part worn through use or accident can only be replaced by an original part identical to the damaged one.

The cars must be strictly series production models identifiable by the homologation form data.

## ARTICLE 5: MINIMUM WEIGHT

The cars must have at least the following weight plus the weight of the safety devices (35 kg) irrespective of what is mentioned in the homologation form.

1600cc upto 1800cc----- 1030 kg + 35 kg = 1065 kg

1800cc upto 2000cc----- 1080 kg + 35 kg = 1115 kg

This is the real weight of the empty car (without persons or luggage aboard) without tools, jack.

All the liquid tanks (lubrication, cooling, braking, heating where applicable) must be at the normal level foreseen by the manufacturer, with the exception of the windscreen wiper or headlight wiper, brake cooling system, fuel and water injection tanks, which shall be empty.

Additional headlights, which do not appear on the homologation form, must be removed before weighing.

## ARTICLE 6:

### 6.1 Engine

- Engine shields made of plastic material, the purpose of which is to hide mechanical components in the engine compartment, may be removed if they have a solely aesthetic function.
- The accelerator cable may be replaced or doubled by another one regardless of whether it comes from the manufacturer or not.
- The screws and bolts may be changed, provided that the replacements are made from ferrous material.
- **Ignition:** The make and type of the spark plugs, rev. limiter and high-tension leads are free.
- The electronic control unit and the ignition components in the electronic control unit are free. The wiring loom is free.
- Sensors and actuators on the input side are free
- The data logging system is free.

- **Compression ratio** – free (permitted to face the block to achieve the desired compression ratio).

**Cylinder head:** Modifications are permitted to the original cylinder head and its components e.g. valves (provided the valve diameter remains as mentioned in the homologation form), valve guides etc.

- All drive pulleys are free - e.g. alternator, crankshaft etc

- In order to accommodate manifolds etc, it is permitted to re-locate components obstructing the fitment of the same

- **Valves:** Free as long as it respects the diameter mentioned in the homologation form. Valve angles have to remain original. Valve springs are free

- **Cylinder head gasket:** Free

- **Camshaft:** Free

- **Timing sprockets:** Free.

- **Engine Block:** The Connecting Rods and Pistons assembly are FREE. Re-boring is permitted (maximum of 0.75 mm.)

- **Flywheel:** The original flywheel may be modified.

- **Cooling system:** Free.

- **Intake System:** Free - Manifold, throttle body, system of operation (carburetted or injection), air-filter and its housing is free.

- **Lubrication:** The fitting of baffles in the oil sump is authorised. Oil filter cartridges are free. Dry sump lubrication is permitted so long as the oil tank is located in the engine compartment.

- **Mountings:** The engine and gearbox mountings are free, but not their numbers. THE ORIGINAL SUPPORT POINTS HAVE TO BE USED.

- **Exhaust** – Free (Manifold to the exit)

These liberties must not entail any bodywork modifications and must respect the laws of the country.

- It is permitted to have an air scoop on the bonnet so long as it does not exceed 7.5cms in height.

## **6.2 Transmission**

### **6.2.1) Clutch:**

The disc and the pressure assembly are free, including the weight, with the exception of the number. The diameter of the clutch disc may be increased.

### **6.2.2) Gearbox:**

The interior of the gearbox is free.

The number of teeth and ratios are free. The joints of the gearbox linkage are free.

### **6.2.3) Differential:**

The use of a mechanical type limited slip differential is authorised, provided that it can be fitted in the series housing

In order to allow its fitting, the interior of the original differential's housing may be modified.

"Mechanical limited slip differential" means any system that works purely mechanically, i.e. without the help of a hydraulic or electric system.

A viscous clutch is not considered to be a mechanical system.

If the homologated vehicle is fitted with a viscous clutch, it may be retained but it will not be possible to add another differential.

### **6.2.4) *Half-shafts*: Free. **Hubs** are Free.**

## **6.3 Suspension**

THE MODIFICATION OF SPRING AND SHOCK ABSORBER ADJUSTMENTS FROM THE COCKPIT IS PROHIBITED

The reinforcing of the structural parts of the suspension (with the exception of anti-roll bars) and its anchorage points by the addition of material is allowed.

The suspension reinforcements must not create hollow sections and must not allow two separate parts to be joined together to form one.

- **Springs:** The spring seats may be adjustable if the adjustable structural part is a part of the spring seat and is separated from the original suspension parts/bodywork (it may be removed).

**Coil springs:** The length is free, as are the number of coils, the wire diameter, the external diameter, the type of spring (progressive or not) and the shape of the spring seats. The number of springs and spring seats is free provided the springs are mounted in series.

- **Leaf springs:** The length, width, thickness and vertical curvature are free.

**Torsion bars:** The diameter is free.

These freedoms on the suspension springs do not authorise one to disregard article 205 of the homologation form (minimum height of the center of the hubcap, wheel passage opening).

- **Shock absorbers:** Free, provided that their number, their type (telescopic, arm, etc.), their working principle (hydraulic, friction, mixed, etc.), and their attachment points remain unchanged.

The checking of the operating principle of the shock absorbers will be carried out as follows:

Once the springs and/or the torsion bars are removed, the vehicle must sink down to the bump stops in less than 5 minutes.

The damper tanks may be attached onto the unmodified shell of the cars.

If the shock absorbers have separate fluid reserves located in the cockpit or in the boot if this is not separated from the cockpit, these must be strongly fixed and must have a protection.

A silent block may be replaced by a **"Uniball" joint**, provided the mounting points remain the same, and is located in the same position as the original one.

Gas filled dampers, regarding their working principle, will be considered as hydraulic dampers.

If, in order to change the damping element of a Mac Pherson suspension, or a suspension operating in an identical manner, it is necessary to replace the entire Mac Pherson strut, the replacement parts must be mechanically equivalent to the original ones and have the same mounting points.

For McPherson suspensions, the shape of the spring seats is free.

Their material is free.

In the case of oil-pneumatic suspension, the spheres may be changed as regards their dimension, shape and material, but not their number.

A tap, adjustable from outside of the car, may be fitted on the spheres.

- **Silent blocks:** Free.

## **6.4 Wheels and tyres**

### **6.4.1) Wheels:**

The wheels are **FREE**,

Wheels made from forged magnesium are forbidden (including standard wheels).

They must be covered by the wings (same checking system as in Group A, article 255.5.4), and a maximum of 20mm increase over the homologated track width is permitted. The means of achieving the track width is free.

Wheel fixations by bolts may be changed to fixations by pins and nuts provided that the number of attachment points and the diameter of the threaded parts as indicated on drawing 254-1 are respected.

Air extractors added on the wheels are forbidden.

### **6.4.2) Tyres:**

Tyres are **FREE** provided that they can be mounted on those wheels. The use of any device for maintaining the performance of the tyre with an internal pressure equal to or less than the atmospheric pressure is forbidden. The interior of the tyre (space between the rim and internal part of the tyre) must be filled only with air.

### **6.4.3) Spare wheel:**

The spare wheel (wheels) is (are) compulsory if mentioned in the homologation form.

The spare wheel may be brought inside the driving compartment, on condition that it is firmly secured there and that it is not installed in the space reserved for the occupants.

## **6.5 Braking system**

With the exception of the modifications authorised by this article, the braking system must be original or homologated in Option Variant (VO).

**- Pressure Regulator: Front and Rear Regulator / Limiter authorised**

Brake linings are free, as well as their mountings (riveted, bonded, etc.) provided that the contact surface of the brakes is not increased.

Protection plates may be removed or bent.

In the case of a car fitted with servo-assisted brakes, this device may be disconnected. The same applies for anti-lock braking systems.

If the anti-lock braking system (ABS) is disconnected or removed, the use of a mechanical rear braking distributor homologated by the manufacturer in VO is authorised.

It is permitted to add a spring in the bore of the callipers.

Brake lines may be changed for aviation type lines.

A device for scraping away the mud that collects on the brake discs and / or the wheels may be added.

### **6.5.1) XXX**

## **6.6 Bodywork**

### **6.6.1) Exterior:**

Hubcaps must be removed.

Protective headlight covers may be fitted provided that their only function is to cover the glass, and that they have no influence on the car's aerodynamics.

The fitting of underbody protections is authorised in rallies only, provided that these really are protections which respect the ground clearance, which are removable and which are designed exclusively and specifically in order to protect the following parts: engine, radiator, suspension, gearbox, tank, transmission, steering, exhaust, extinguisher bottles. Underbody protections may extend the whole width of the underside part of the front bumper only in front of the front wheel axis.

Plastic soundproofing parts may be removed from the wheel openings.

These plastic elements may be changed for aluminium or plastic elements of the same shape.

Any locking system may be used for the cap of the petrol tank.

The changing of the front and rear windscreen wiper blades is authorised.

#### **6.6.2) Interior:**

The front seats may be moved backwards but not beyond the vertical plane defined by the front edge of the original rear seat.

The limit relating to the front seat is formed by the height of the seat without the headrest, and if the headrest is incorporated into the seat, by the rearmost point of the driver's shoulders.

The rear seats may be removed.

The rear safety belts may be removed.

**6.6.2.1) Should the fuel tank** be installed in the boot and the rear seats removed, a fireproof and liquid-proof bulkhead must separate the cockpit from the fuel tank.

In the case of twin-volume cars it will be possible to use a non-structural partition wall in transparent, non-flammable plastic between the cockpit and the tank arrangement.

**6.6.2.2) Dashboard:**

The dashboard is free. The central console may be removed

**6.6.2.3) Doors – Door side trim:**

It is permitted to remove the soundproofing material from the doors, provided that this does not modify the shape of the doors.

It is permitted to remove the original trim (door pads) from the doors provided a fabricated trim is installed in its place.

It is permitted to replace electric winders with manual ones.

**6.6.2.4) Floor**

Carpets are free and may thus be removed.

**6.6.2.5) Other sound-proofing materials and trim:**

Other soundproofing materials and trim, except for those mentioned under articles 6.6.2.3 (Doors) and 6.6.2.2 (Dashboard) may be removed.

**6.6.2.6) Heating system:**

The original heating equipment may be retained. The following parts of the air conditioning system may be removed: condenser and auxiliary fan, fluid tank, evaporator and fan, expansion valve, as well as all pipes, connections, contact switches, sensors and actuators necessary for the functioning of the system.

The compressor may be rendered inoperative or removed.

**6.6.2.7)** The removable rear shelf in twin-volume cars may be removed.

**6.6.3) Additional accessories:**

All those, which have no, influence on the car's behaviour, for example equipment that improves the aesthetics or comfort of the car interior (lighting, heating, radio, etc.), are allowed without restriction.

In no case may these accessories increase the engine power or influence the steering, transmission, brakes, or roadholding, even in an indirect fashion.

All controls must retain the role laid down for them by the manufacturer.

They may be adapted to facilitate their use and accessibility, for example a longer handbrake lever, an additional flange on the brake pedal, etc.

**The following is allowed:**

1) Measuring instruments such as speedometers etc. may be installed or replaced, and possibly have different functions. Such installations must not involve any risk. However, the speedometer may not be removed if the supplementary regulations of the event prevent this.

2) The horn may be changed and/or an additional one added, within reach of the passenger.

The horn is not compulsory on closed roads.

3) The handbrake locking mechanism may be removed in order to obtain instant unlocking (fly-off handbrake).

4) The steering wheel is free. The locking system of the anti-theft steering lock may be rendered inoperative.

5) Additional compartments may be added to the glove compartment and additional pockets in the doors, provided that they use the original panels.

6) Insulating material may be added to the existing bulkheads to protect the passengers from fire.

**6.6.4) Reinforcements:**

Reinforcement bars may be fitted on the suspension mounting points to the bodyshell or chassis of the same axle, on each side of the car's longitudinal axis, on condition that they are removable and are attached by means of bolts.

The distance between a suspension attachment point and an anchorage point of the bar cannot be more than 100 mm, unless the bar is a transversal strut homologated with the rollbar, or unless it is an upper bar attached to a MacPherson suspension or similar.

In the latter case, the maximum distance between an anchorage point of the bar and the upper articulation point will be 150 mm (drawings 255-4 and 255-2).

Apart from these points, this bar must not be mounted on the bodyshell or the mechanical parts. Strengthening of the suspended part is allowed provided that the material used follows the original shape and is in contact with it.

**6.6.5) When the spare wheel** is originally set in a closed accommodation, and when this wheel is changed for a thicker one (see article 6.4), situated in this space, it is possible to remove from the cover of the location of the wheel the surface induced by the diameter of the new wheel (drawing 254-2).

## 6.7 Electrical system

- **Battery:** The make, capacity, and battery cables are free. The tension and the site of the battery may be changed

A power take-off connected to the battery is permitted in the passenger space.

- **Generator:** May be replaced by a more powerful one. A dynamo may not be replaced by an alternator and vice-versa.

- **Lighting system:** Additional headlights including the corresponding relays are allowed, provided that the total does not exceed eight (tail and parking lights not included) and that this is accepted by the laws of the country.

They may not be housed within the bodywork. Headlights and other exterior lights must always exist in pairs.

The original headlights can be made inoperative and covered with adhesive tape.

They can be replaced by other headlights, in compliance with this article.

**A reversing light** may be fitted provided it can only be used when the gear lever is in the "reverse" position, and provided that the police regulations on this subject are observed.

- **Fuses may** be added to the electrical system.

## 6.8 Fuel circuit

Providing the original tank is equipped with an electric pump and an interior filter, it is possible when using an FT3 or FT3 1999 tank or another tank homologated by the manufacturer on the car's homologation form to place a filter and a pump with identical characteristics to the homologated one outside.

These parts must be protected in adequate fashion.

The fitting of a second fuel pump is authorised, but this must be only a spare fuel pump, i.e. it cannot operate in addition to the authorized pump. It must be connectable only when the car is immobile and by means of a purely mechanical device situated beside the pumps.

The filler holes may not be located in the window panels.

Fuel lines must be changed for aviation type lines if an FT3 or FT3 1999 tank is used, the route of these lines being free. Should a series production tank be used, this change is optional.

The total capacity of the tanks must not exceed that indicated in article 401.d of the Group N homologation form, except for rallies, if the car is fitted with FT3 or FT3 1999 tanks.

In this case, the total capacity of the tanks must not exceed the following limits, in relation to the engine capacity:

upto 700 cc : 60 ltrs  
over 700 cc and upto 1000 cc : 70 ltrs  
over 1000 cc and upto 1400cc : 80 ltrs  
over 1400 cc : 95 ltrs

For twin-volume cars homologated from 01.01.98 with a fuel tank installed in the luggage compartment, a fireproof and liquid-proof case must surround the fuel tank and its filler holes.

For three-volume cars homologated from 01.01.98, a fireproof and liquid-proof bulkhead must separate the cockpit from the fuel tank. Nevertheless, it is recommended that this liquid-proof bulkhead be replaced by a liquid-proof case as for twin-volume cars.

## 6.9 Jack

The jacking points may be strengthened, moved and increased in number. These modifications are limited exclusively to the jacking points.

\*\* END \*\*

FMSCI

**2009 Technical Regulations  
Specific Regulations for Rally Star Cup  
Classification & Definitions, General Prescriptions  
and Safety Equipment**

*With effect from January 2009*

All matters regarding the above, not specifically covered by these Regulations should be read as per FMSCI Regulations I, II, III and IV - 2009.

**ARTICLE 1: DEFINITION**

Large scale series production touring cars; Maruti Esteem 1300cc carburetted versions only.

**ARTICLE 2: HOMOLOGATION**

Maruti Esteem 1300cc carburetted versions only. Type I and Type II.

The brakes, steering and engines and / or their internal components could be freely interchanged in the different models of the Maruti Esteem (Type I / Type II) applicable to carburetted versions only.

**ARTICLE 3: NUMBER OF SEATS**

The rear seats may be removed.

SEATS WITH HEAD RESTS ARE MANDATORY

-FIA HOMOLOGATED SEATS ARE RECOMMENDED

THE TECHNICAL DELEGATE IS THE FINAL AUTHORITY ON THE CONDITION AND SAFETY OF THE SEATS USED

**ARTICLE 4: MODIFICATIONS AND ADJUNCTIONS ALLOWED OR OBLIGATORY**

All the modifications which are not allowed by the present Regulations are expressly forbidden.

The only work which may be carried out on the car is that necessary for its normal servicing, or for the replacements of parts worn through use or accident.

The limits of the modifications and fittings allowed are specified hereinafter.

Apart from these, any part worn through use or accident can only be replaced by an original part identical to the damaged one. (No abrasive material may be used, which may cause a change to the surface finish of engine components (e.g. cylinder head ports, exhaust and inlet manifolds, pistons, connecting rods, cylinder head combustion chambers, carburettors, valves, and valve guides) - the finish of the component should be as supplied by the manufacturer.)

Blue printing of engines is not permitted.

However it is permitted to machine the following parts.

- 1). It is permitted to machine the gasket plane of the cylinder block, so long as Article 311 and Article 317 of the homologation form is respected.
- 2). It is permitted to machine the gasket plane of cylinder head, so long as Article 309 of the homologation form is respected. The finish of the combustion chamber should be as supplied by the manufacturer.

The cars must be strictly series production models identifiable by the homologation form data.

#### **ARTICLE 5: MINIMUM WEIGHT**

The minimum weight of all Maruti Esteems will be 770kg.

This is the real weight of the empty car (without persons or luggage aboard) without tools, jack.

All the liquid tanks (lubrication, cooling, braking, heating where applicable) must be at the normal level foreseen by the manufacturer, with the exception of the windscreen wiper, which shall be empty.

Additional headlights which do not appear on the homologation form must be removed before weighing.

(As per FMSCI Regulations 2009)

As far as rollcages which cannot be removed from the car, and which were manufactured in accordance with FMSCI Technical Regulations Group N – III Articles 8.2 and 8.3, are concerned, the following weights will be taken as a basis:

- Rollcage according to drawings 253-3/4: 30 kg
- Rollcage according to drawings 253-5 to 17C: 35 kg

## ARTICLE 6:

### 6.1 Engine

- Engine shields made of plastic material, the purpose of which is to hide mechanical components in the engine compartment, may be removed if they have a solely aesthetic function.
- The accelerator cable may be replaced or doubled by another one regardless of whether it comes from the manufacturer or not.
- The screws and bolts may be changed, provided that the replacements are made from ferrous material.
- **Ignition:** The make and type of the spark plugs and high-tension leads are free.
- **Cooling system:** The thermostat is free, as is the control system and the temperature at which the fan cuts in.

Locking system for the radiator cap is free.

A fabricated shield may be incorporated in place of the AC condenser.

- **Carburettors:** The original system must be retained.

The components of the carburettor which control the quantity of petrol entering the combustion chamber may be modified, provided that they do not have any influence over the quantity of air admitted.

Replacement air filter cartridges are accepted in the same way as the original ones. **Removal of all elements between Air Filter Box and Resonator is permitted.**

- **Fuel Pumps:** A secondary fuel pump may be fitted for which the electrical wiring is free.

- **Lubrication:** The fitting of baffles in the oil sump is authorised.

Replacement oil filter cartridges are accepted in the same way as the original ones.

- The material of the elastic part of the engine and gearbox mountings is free, but not the number of mountings.

- **Exhaust:**

It will be possible either to remove the inside of the original silencer, or to modify the exhaust from the first silencer to the exit, the maximum dimensions of the duct being those of the pipe situated upstream of the first silencer.

Should two inlets exist in the first silencer, the section of the modified duct must be less than or equal to the total of the two original sections.

Only one pipe may be present at the exit, unless the original part is used.

The exit should be situated in the same position as that of the series production exhaust system.

These liberties must not entail any bodywork modifications and must respect the laws of the country in which the event is run with regard to noise levels.

Additional parts for the mounting of the exhaust are authorised.

The catalytic converter is considered as a silencer.

(As per FMSCI Regulations 2009)

## **6.2 Transmission**

### **6.2.1) Clutch:**

Only OE Components permitted.

**6.2.2) Gearbox:**

No modifications permitted

**6.2.3) Differential:**

FMSCI Rally Star Cup approved Differential Gear cages are permitted.

4 – Pinion Differential case is permitted, so long as it fits in the original housing. Locking methods of the differential pin is free.

**6.2.4) Half-shafts:**

Only original Equipment or FMSCI Rally Star Cup approved Half Shafts is permitted.

**6.3 Suspension**

The reinforcing of the structural parts of the suspension (with the exception of anti-roll bars) and its anchorage points by the addition of material is allowed.

**- Springs:**

Original Equipment or FMSCI Rally Star Cup approved components are permitted.

**- Shock absorbers:**

OE SUSPENSION AS SUPPLIED BY THE MANUFACTURER

OR

KONI SHOCK ABSORBERS (STRUTS) ARE PERMITTED  
FRONT – SUZUKI SWIFT - KONI SPORT – (YELLOW IN COLOR – ADJUSTABLE) PART NUMBER – 86 – 2588 (INSERTS)

REAR - SUZUKI SWIFT – KONI SPORT–(YELLOW IN COLOR – ADJUSTABLE) – PART NUMBER – 87 - 2429

NO MODIFICATIONS ARE PERMITTED ON THE KONI SHOCK ABSORBERS

OR

FMSCI APPROVED SHOCK ABSORBERS

**- Spacers:**

The use of spacers for the front and rear suspension is allowed so long as it forms a part of the strut and the mounting points of the strut remain unchanged (the spacer can not be a separate component) provided:

Front Strut spacer (for increasing ride height) - maximum 25mm

Rear Strut Spacer (for increasing ride height) - maximum 25mm

**6.4 Wheels and tyres**

**6.4.1) Wheels:**

The wheels are free, respecting the homologated maximum diameter and maximum width. They must be covered by the wings and the maximum track given on the homologation form must be respected. (801a and 801b)

**6.4.2) Tyres:**

Tyres are FREE provided they are made in India and can be fitted on those wheels. These tyres must have the words 'Made in India' as part of the original mould with the words visible on the tyres. OR a tyre can be an OE component supplied by a vehicle manufacturer in India.

The tyre should be freely available.

The use of any device for maintaining the performance of the tyre with an internal pressure equal to or less than the atmospheric pressure is forbidden. The interior of the tyre (space between the rim and internal part of the tyre) must be filled only with air.

**6.4.3) Spare wheel:**

The spare wheel is mandatory. The spare wheel may be brought inside the driving compartment, on condition that it is firmly secured there and that it is not installed in the space reserved for the occupants.

## **6.5 Braking system**

No modification permitted

### **6.5.1) Handbrake:**

Fly-off hand brake is permitted.

## **6.6 Bodywork**

### **6.6.1) Exterior :**

A fabricated shield may be incorporated in place of an AC condenser.

Hubcaps must be removed.

The fitting of underbody protections is authorised in rallies only, provided that these really are protections which respect the ground clearance, which are removable and which are designed exclusively and specifically in order to protect the following parts: engine, radiator, suspension, gearbox, tank, transmission, steering, exhaust, extinguisher bottles.

### **6.6.2) Interior :**

The front seats may be moved backwards but not beyond the vertical plane defined by the front edge of the original rear seat.

The limit relating to the front seat is formed by the height of the seat without the headrest, and if the headrest is incorporated into the seat, by the rearmost point of the driver's shoulders.

The rear seats may be removed.

The rear safety belts may be removed.

#### **6.6.2.1) Dashboard:**

The dashboard must remain original.

#### **6.6.2.2) Doors - Side trim:**

The original door pads may be removed and replaced with any door pad / fabricated one.

It is permitted to replace electric winders with manual ones.

#### **6.6.2.3) Floor**

Carpets are free and may thus be removed.

#### **6.6.3) Additional accessories:**

All those which have no influence on the car's behaviour, for example equipment which improves the aesthetics or comfort of the car interior (lighting, heating, radio, etc.), are allowed without restriction.

In no case may these accessories increase the engine power or influence the steering, transmission, brakes, or roadholding, even in an indirect fashion.

All controls must retain the role laid down for them by the manufacturer. They may be adapted to facilitate their use and accessibility, for example a longer handbrake lever, an additional flange on the brake pedal, etc.

The following is allowed:

- 1) Measuring instruments such as speedometers etc. may be installed or replaced, and possibly have different functions. Such installations must not involve any risk.
- 2) The handbrake locking mechanism may be removed in order to obtain instant unlocking (fly-off handbrake).
- 3) The steering wheel is free.

The locking system of the anti-theft steering lock may be rendered inoperative.

- 4) Additional compartments may be added to the glove compartment and additional pockets in the door pads.

5) Insulating material may be added to the existing bulkheads to protect the passengers from fire.

#### **6.6.4) Reinforcements :**

Reinforcement bars may be fitted on the suspension mounting points to the bodyshell or chassis of the same axle, on each side of the car's longitudinal axis, on condition that they are removable and are attached by means of bolts.

#### **6.7 Electrical system**

- **Battery:** The make, capacity, and battery cables are free. The tension and the site of the battery must be retained.
- **Generator:** May be replaced by a more powerful one. A dynamo may not be replaced by an alternator and vice-versa.
- **Lighting system:** Additional headlights including the corresponding relays are allowed, provided that the total does not exceed eight (tail and parking lights not included) and that this is accepted by the laws of the country.

They may not be housed within the bodywork. Headlights and other exterior lights must always exist in pairs.

The original headlights can be made inoperative and covered with adhesive tape. They can be replaced by other headlights, in compliance with this article.

A reversing light may be fitted provided it can only be used when the gear lever is in the "reverse" position, and provided that the police regulations on this subject are observed.

- Fuses may be added to the electrical system.

#### **6.8 Fuel circuit**

An additional fuel pump may be fitted.

## 6.9 Jack

The jacking points may be strengthened, moved and increased in number. These modifications are limited exclusively to the jacking points.

### **ARTICLE 7: Roll Cages**

Cold drawn seamless unalloyed carbon steel tube (Containing a maximum of 0.3% of carbon) with a minimum tensile strength of 350 N/mm<sup>2</sup>

The minimum dimensions being 45mm X 2.5mm or 50mm X 2mm.

The basic minimum structural requirement as per Drawing 253-3 and FMSCI Regulations 2009

### **ARTICLE 8: Seat Belts**

Minimum required is a four point harness and following the technical drawings regarding mounting points (Article 253 – 42 to 45, 52 and 53 of Appendix J – FIA Regulations)

### **ARTICLE 9: Fire Extinguishers**

Fire Extinguishers to be rigidly fastened with a quick release clamp FITTED IN AN EASILY ACCESSIBLE AND A VISIBLE POSITION.

Specifications - as per FMSCI Regulations

As per FMSCI Regulations 2009

### **ARTICLE 10: Side and Rear Windows**

The use of transparent or colourless anti shatter film on the side windows is mandatory.

### **ARTICLE 11: Laminated Windshield**

Laminated windshield is mandatory.

**ARTICLE 12: Presentability of Cars**

All cars taking the ramp should be presentable in appearance.

**ARTICLE 13: A/C and Heating**

The components relating to the A/C and Heating may be removed so long as the homologated weight of the car is maintained.

**ARTICLE 14: Reinforcement of Aprons (Front)**

It is permitted to add a member between the front aprons above the front cross member (the front jacking point) provided it is removable and mounted only by means of bolt & nuts.

**\*\* END \*\***

**2009 Technical Regulations  
Maruti Gypsy Class**

**Classification & Definitions, General Prescriptions  
and Safety Equipment**

*With effect from January 2009*

All matters regarding the above, not specifically covered by these Regulations should be read as per FMSCI Regulations I, II, III and IV – 2009. (Group N)

**ARTICLE 1: DEFINITION**

Large-scale series production touring cars; Maruti Gypsy 1000cc, 1300cc and 1300cc MPFI.

**ARTICLE 2: HOMOLOGATION**

Maruti Gypsy 1000cc (Maruti Gypsy Narrow Track and Wide Track), 1300cc and 1300cc MPFI.

The brakes, steering, radiators and engines or their internal components could be freely interchanged in the different models of the Maruti Gypsy 1000cc.

Fitting of a MPFI 1300 Engine into another shell of Maruti Gypsy is permitted, so long as it conforms to a homologation form, presented.

The FRONT HUB ASSY, LOCKING may be interchanged with the locking assembly, of the 1300cc models or the 1000cc model

**ARTICLE 3: NUMBER OF SEATS / BODY SHELL**

The rear seats may be removed.

A metal / hard top cabin must be used in place of the soft-top cabin. A rear half cabin is permitted.

**SEATS WITH HEAD RESTS ARE MANDATORY**

**-FIA HOMOLOGATED SEATS ARE RECOMMENDED**

THE TECHNICAL DELEGATE IS THE FINAL AUTHORITY ON THE CONDITION AND SAFETY OF THE SEATS USED

**ARTICLE 4: MODIFICATIONS AND ADJUNCTIONS ALLOWED OR OBLIGATORY**

All the modifications which are not allowed by the present Regulations are expressly forbidden.

The only work which may be carried out on the car is that necessary for its normal servicing, or for the replacements of parts worn through use or accident.

The limits of the modifications and fittings allowed are specified hereinafter. Apart from these, any part worn through use or accident can only be replaced by an original part identical to the damaged one. (No abrasive material may be used, which may cause a change to the surface finish of engine components (e.g. cylinder head ports, exhaust and inlet manifolds, pistons, connecting rods, cylinder head combustion chambers, carburetors, valves, and valve guides) - the finish of the component should be as supplied by the manufacturer.)

**BLUE PRINTING OF ENGINES IS NOT PERMITTED**

However it is permitted to machine the following parts.

- 1). It is permitted to machine the gasket plane of the cylinder block, so long as Article 311 and Article 317 of the homologation form is respected.
- 2). It is permitted to machine the gasket plane of cylinder head, so long as Article 309 of the homologation form is respected. The finish of the combustion chamber should be as supplied by the manufacturer.

The cars must be strictly series production models identifiable by the homologation form data.

**ARTICLE 5: MINIMUM WEIGHT**

The minimum weight of all Maruti Gypsy, irrespective of the weight mentioned in the homologation form will be: Narrow Track / Wide Track - 910kg

This is the real weight of the empty car (without persons or luggage aboard) without tools, jack. All the liquid tanks (lubrication, cooling, braking, heating where applicable) must be at the normal level foreseen by the manufacturer, with the exception of the windscreen wiper, which shall be empty.

Additional headlights which do not appear on the homologation form must be removed before weighing.

As far as rollcages which cannot be removed from the car, and which were manufactured in accordance with FMSCI Technical Regulations Group N – III Articles 8.2 and 8.3, are concerned, the following weights will be taken as a basis:

- Rollcage according to drawings 253-3/4: 30 kg
- Rollcage according to drawings 253-5 to 17C: 35 kg

## ARTICLE 6:

### 6.1 Engine

- Engine shields made of plastic material, the purpose of which is to hide mechanical components in the engine compartment, may be removed if they have a solely aesthetic function.
- The accelerator cable may be replaced or doubled by another one regardless of whether it comes from the manufacturer or not.
- The screws and bolts may be changed, provided that the replacements are made from ferrous material.
- **Ignition:** The make and type of the spark plugs and high-tension leads are free.
- **Cooling system:** The thermostat is free, as is the control system and the temperature at which the fan cuts in. Radiators can be interchanged from another model of the Gypsy. **The radiators are FREE. The cooling fan is FREE and fitting of double Radiators and two Cooling Fans are permitted.**
- **Locking system** for the radiator cap is free.
- **Carburettors:** The original system must be retained.

The components of the carburettor which control the quantity of petrol entering the combustion chamber may be modified, provided that they do not have any influence over the quantity of air admitted.

**Air Filters** – FREE (Air Filtration methods are free upto the carburettor or the throttle body).

- **Lubrication:** The fitting of baffles in the oil sump is authorised.

Replacement oil filter cartridges are accepted in the same way as the original ones.

- The material of the elastic part of the engine and gearbox mountings is free, but not the number of mountings.

- **Exhaust** - FREE. (Exhaust manifold to the exit is free.)

However the exhaust ports in the cylinder head should remain as provided by the manufacturer.

- The noise levels on the open road must not exceed 103dB(A) for an engine rotation speed of 3500 rpm for petrol engines and 2500 rpm for diesel engines

- The location of the exit of the exhaust pipe is free

- The exhaust system must not be provisional

- Exhaust gases may only exit at the end of the system

These liberties must not entail any bodywork modifications and must respect the laws of the country in which the event is run with regard to noise levels.

Additional parts for the mounting of the exhaust are authorised.

## 6.2 Transmission

### 6.2.1) Clutch:

Only OE Components permitted.

### **6.2.2) Gearbox:**

No modifications permitted.

### **6.2.3) Differential:**

No modifications are permitted. However, it is permitted to strengthen the differential housings.

Welding or locking of the differential pin (spider pin) to the differential cage is permitted

## **6.3 Suspension**

The reinforcing of the structural parts of the suspension (with the exception of anti-roll bars) and its anchorage points by the addition of material is allowed.

### **- Springs:**

It is allowed to add additional spring blades but their mounting points should remain original.

### **- Shock absorbers:**

Free. Additional shock absorbers are permitted.

## **6.4 Wheels and tyres**

### **6.4.1) Wheels:**

The wheels are free, respecting the homologated maximum diameter (article 801.a), and maximum width (article 801.b).

The use of wheels with lesser dimensions is permitted.

Wheels made from forged magnesium are forbidden (including standard wheels).

They must be covered by the wings (same checking system as in Group A, article 255.5.4), and the maximum track given on the homologation form must be respected.

Wheel fixations by bolts may be changed to fixations by pins and nuts provided that the number of attachment points and the diameter of the threaded parts as indicated on drawing 254-1 are respected.

Air extractors added on the wheels are forbidden.

#### **6.4.2) Tyres:**

Tyres are FREE provided that they can be mounted on those wheels.

The use of any device for maintaining the performance of the tyre with an internal pressure equal to or less than the atmospheric pressure is forbidden. The interior of the tyre (space between the rim and internal part of the tyre) must be filled only with air.

#### **6.4.3) Spare wheel:**

The spare wheel (wheels) is (are) compulsory if mentioned in the homologation form.

The spare wheel may be brought inside the driving compartment, on condition that it is firmly secured there and that it is not installed in the space reserved for the occupants.

### **6.5 Braking system**

No modification permitted

#### **6.5.1) Handbrake:**

Fly-off hand brake is permitted.

### **6.6 Bodywork**

#### **6.6.1) Exterior :**

The fitting of underbody protections is authorised in rallies only, provided that these really are protections which respect the ground clearance, which are removable and which are designed exclusively and specifically in order to protect the following parts: engine, radiator, suspension, gearbox, tank, transmission, steering, exhaust, extinguisher bottles.

#### **6.6.2) Interior :**

The front seats may be moved backwards but not beyond the vertical plane defined by the front edge of the original rear seat.

The limit relating to the front seat is formed by the height of the seat without the headrest, and if the headrest is incorporated into the seat, by the rearmost point of the driver's shoulders.

**6.6.2.1) Dashboard:**

The dashboard must remain original.

**6.6.2.2) Doors - Side trim:**

The original door pads may be removed and replaced with any door pad / fabricated one.

It is permitted to replace electric winders with manual ones.

**6.6.2.3) Floor**

Carpets are free and may thus be removed.

**6.6.3) Additional accessories:**

All those which have no influence on the car's behavior, for example equipment which improves the aesthetics or comfort of the car interior (lighting, heating, radio, etc.), are allowed without restriction.

In no case may these accessories increase the engine power or influence the steering, transmission, brakes, or roadholding, even in an indirect fashion.

All controls must retain the role laid down for them by the manufacturer.

They may be adapted to facilitate their use and accessibility, for example a longer handbrake lever, an additional flange on the brake pedal, etc.

The following is allowed:

- 1) Measuring instruments such as speedometers etc. may be installed or replaced, and possibly have different functions. Such installations must not involve any risk.
- 2) The handbrake locking mechanism may be removed in order to obtain instant unlocking (fly-off handbrake).
- 3) The steering wheel is free.

The locking system of the anti-theft steering lock may be rendered inoperative.

4) Additional compartments may be added to the glove compartment and additional pockets in the door pads.

5) Insulating material may be added to the existing bulkheads to protect the passengers from fire.

#### **6.6.4) Reinforcements:**

Reinforcement bars may be fitted on the suspension mounting points to the bodyshell or chassis of the same axle, on each side of the car's longitudinal axis, on condition that they are removable and are attached by means of bolts.

#### **6.7 Electrical system**

- **Battery:** The make, capacity, and battery cables are free. The tension and the site of the battery must be retained.

- **Generator:** May be replaced by a more powerful one. A dynamo may not be replaced by an alternator and vice-versa.

- **Lighting system:** Additional headlights including the corresponding relays are allowed, provided that the total does not exceed eight (tail and parking lights not included) and that this is accepted by the laws of the country.

They may not be housed within the bodywork. Headlights and other exterior lights must always exist in pairs.

The original headlights can be made inoperative and covered with adhesive tape. They can be replaced by other headlights, in compliance with this article.

A reversing light may be fitted provided it can only be used when the gear lever is in the "reverse" position, and provided that the police regulations on this subject are observed.

- Fuses may be added to the electrical system.

### **6.8 Fuel circuit**

An additional fuel pump may be fitted. The electrical wiring for the same is free.

### **6.9 Jacking Points**

The jacking points may be strengthened, moved and increased in number. These modifications are limited exclusively to the jacking points.

### **ARTICLE 7: Roll Cages**

Cold drawn seamless unalloyed carbon steel tube (Containing a maximum of 0.3% of carbon) with a minimum tensile strength of 350 N/mm<sup>2</sup>

The minimum dimensions being 45mm X 2.5mm or 50mm X 2mm.

The basic minimum structural requirement as per Drawing 253-3 and FMSCI Regulations 2009

### **ARTICLE 8: Seat Belts**

Minimum required is a four-point harness and following the technical drawings regarding mounting points as per FMSCI Regulations.

### **ARTICLE 9: Fire Extinguishers**

Fire Extinguishers to be rigidly fastened with a quick release clamp **FITTED IN AN EASILY ACCESSIBLE AND A VISIBLE POSITION.**

Specifications – as per FMSCI Regulations

### **ARTICLE 10: Side and Rear Windows**

The use of transparent or colourless anti shatter film on the side windows is mandatory.

### **ARTICLE 11: Laminated Windshield**

Laminated windshield is mandatory.

**ARTICLE 12: A/C and Heating**

The components relating to the A/C and Heating may be removed so long as the homologated weight of the car is maintained.

**ARTICLE 13: Additional Locking Mechanisms**

Additional locking mechanisms between the engine mounting and the chassis is permitted.

**ARTICLE 14: Propeller shaft guards**

Propeller shaft guards or chains are mandatory.

**ARTICLE 15: Presentability of Cars**

All cars taking the ramp should be presentable in appearance.

**\*\* END \*\***

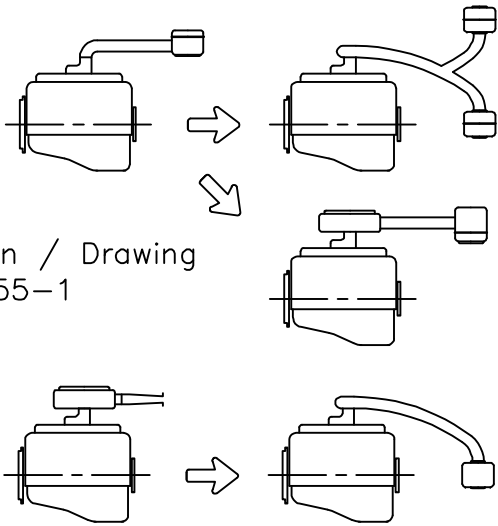

Dessin / Drawing  
N° 255-1

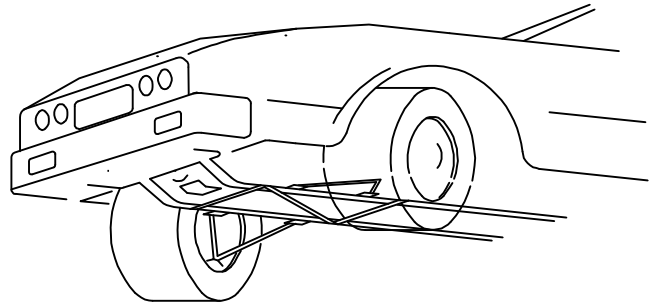

Dessin / Drawing N°255-2

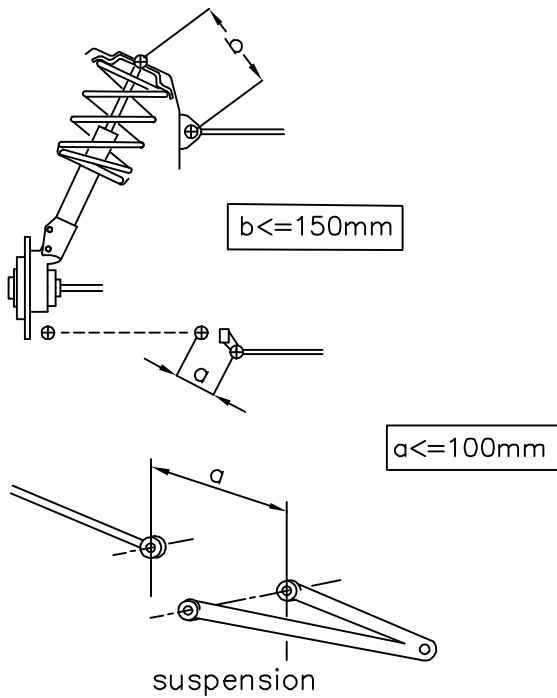

Dessin / Drawing N°255-4

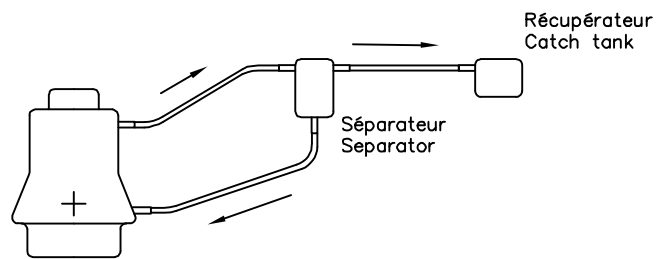

Dessin / Drawing N°255-3

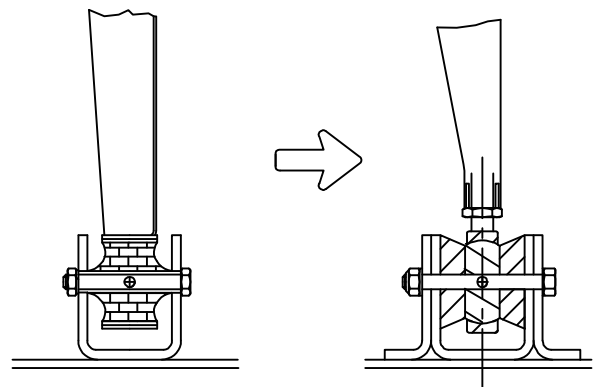

Dessin / Drawing N°255-5

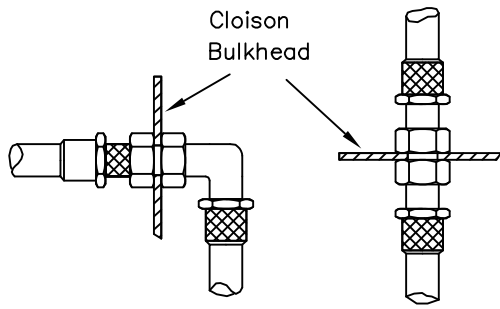

Dessin / Drawing N° 253-1

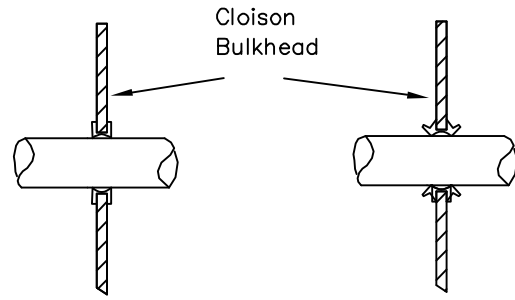

Dessin / Drawing N° 253-2

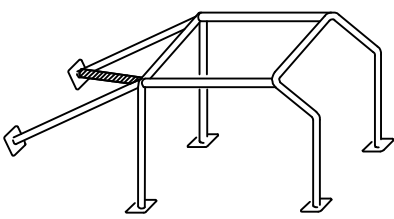

Dessin / Drawing N° 253-3

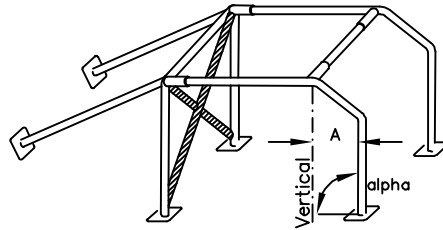

Dessin / Drawing N° 253-4

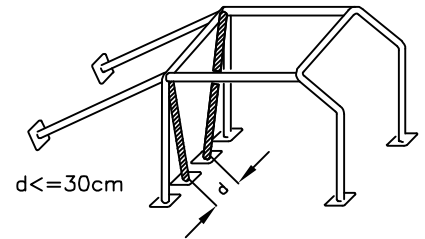

Dessin / Drawing N° 253-5

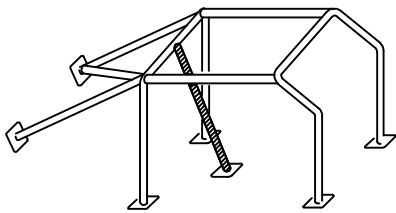

Dessin / Drawing N° 253-6

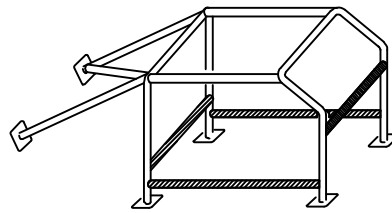

Dessin / Drawing N° 253-7

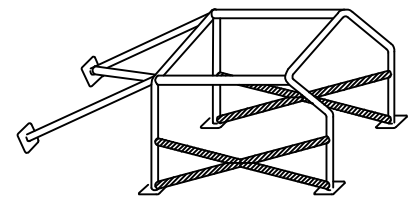

Dessin / Drawing N° 253-8

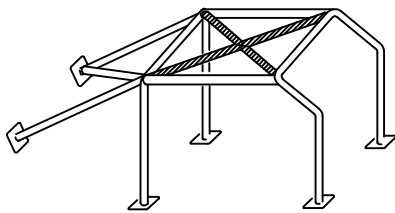

Dessin / Drawing N° 253-9

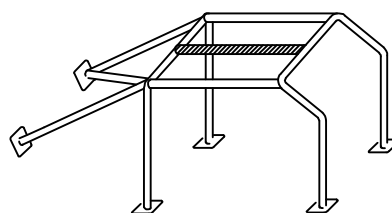

Dessin / Drawing N° 253-9A

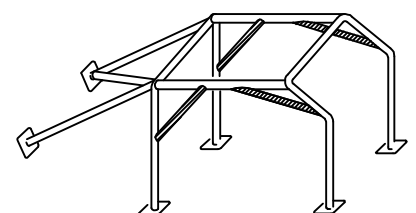

Dessin / Drawing N° 253-10

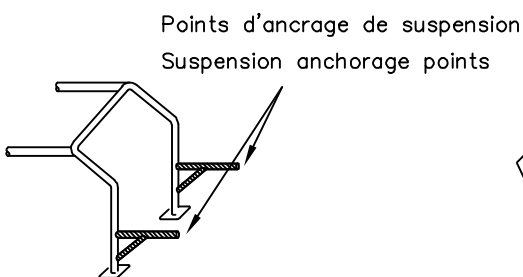

Dessin / Drawing N° 253-11

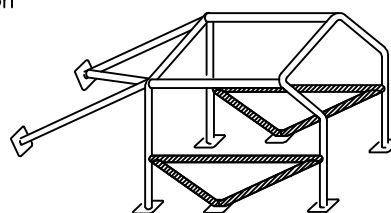

Dessin / Drawing N° 253-12

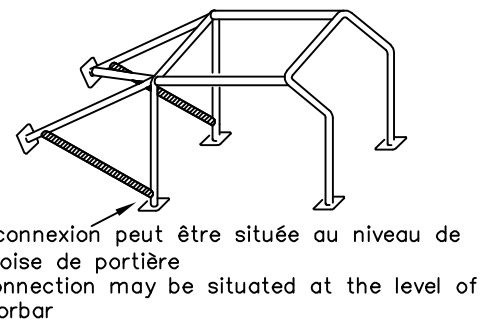

Dessin / Drawing N° 253-13

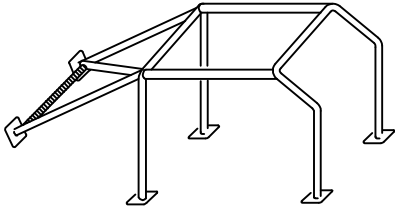

Dessin / Drawing N°253-14

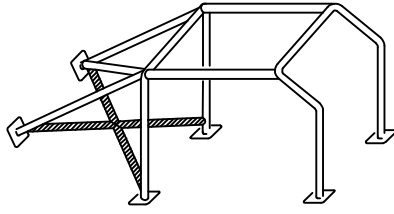

Dessin / Drawing N°253-15

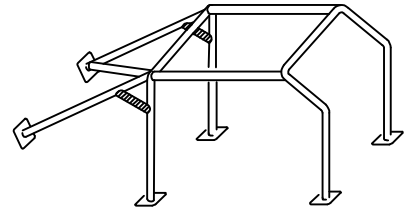

Dessin / Drawing N°253-16

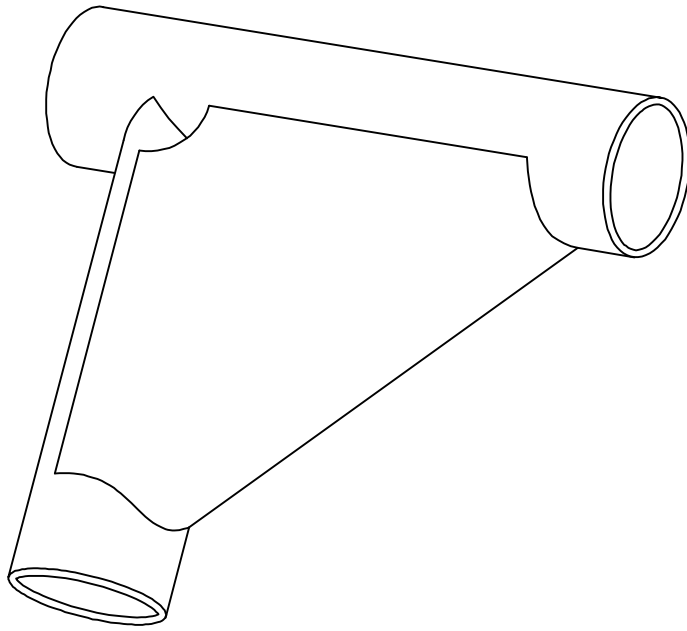

Dessin / Drawing N°253-16A

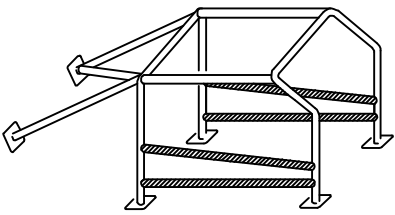

Dessin / Drawing N°253-17

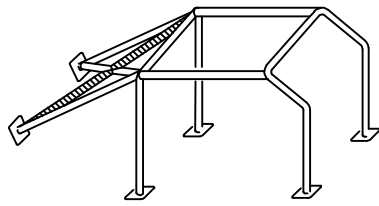

Dessin / Drawing N°253-17A

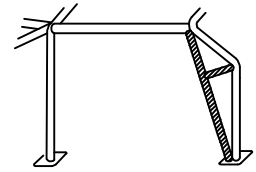

Dessin / Drawing N°253-17B

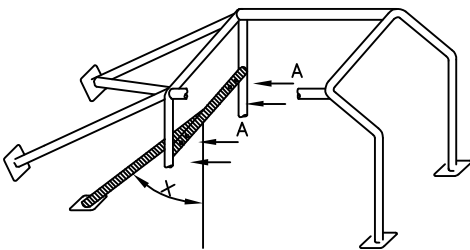

Ⓐ Trous de montage pour harnais  
Mounting holes for harnesses

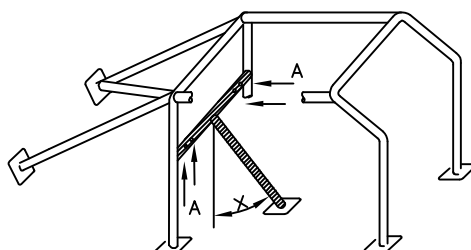

ⓧ Angle minimum 30°  
Minimum angle 30°

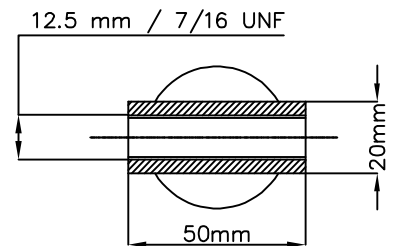

Agrandissement de A  
Magnification of A

Dessin / Drawing N°253-17C

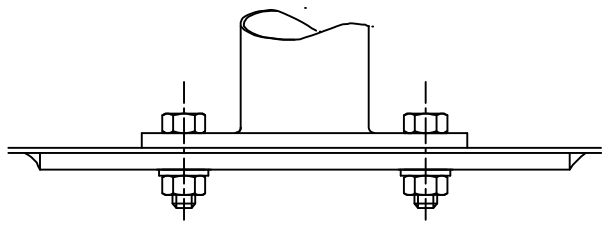

Dessin/Drawing N°253-18

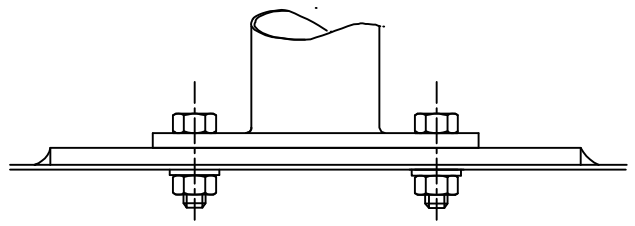

Dessin/Drawing N°253-19

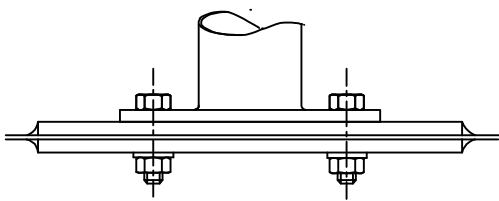

Dessin/Drawing N°253-20

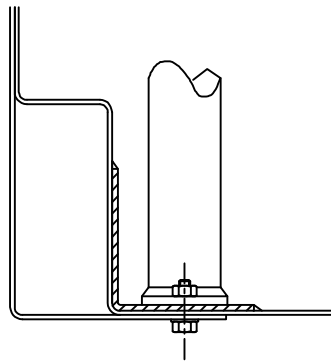

Dessin/Drawing N°253-21

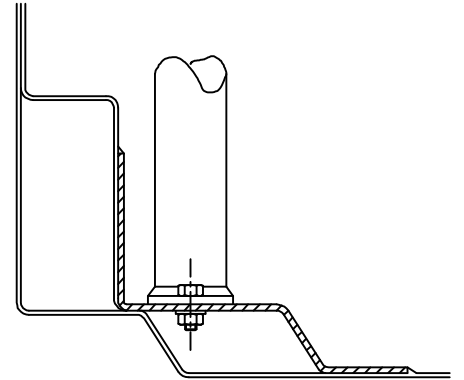

Dessin/Drawing N°253-22

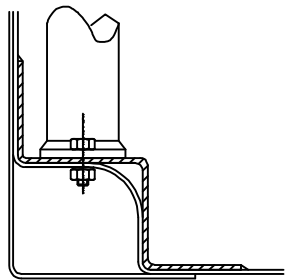

Dessin/Drawing N°253-23

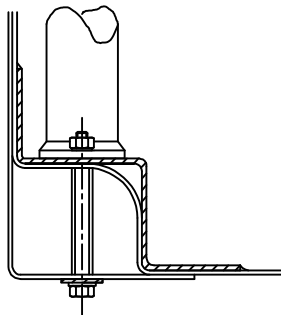

Dessin/Drawing N°253-24

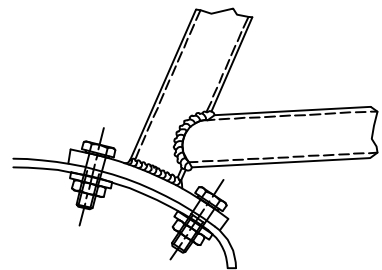

Dessin/Drawing N°253-25

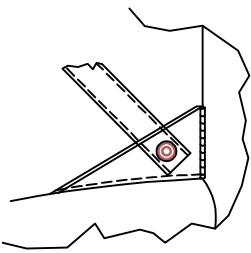

Dessin/Drawing N°253-26

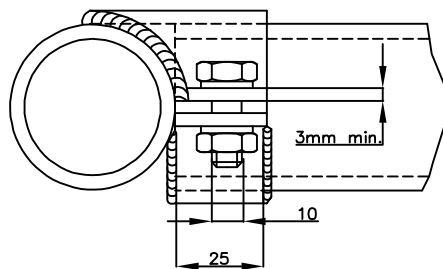

Dessin/Drawing N°253-27

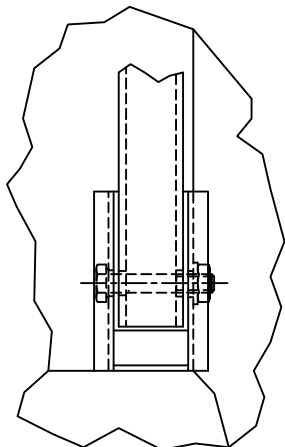

Direction d'application de la charge  
Direction of applied load

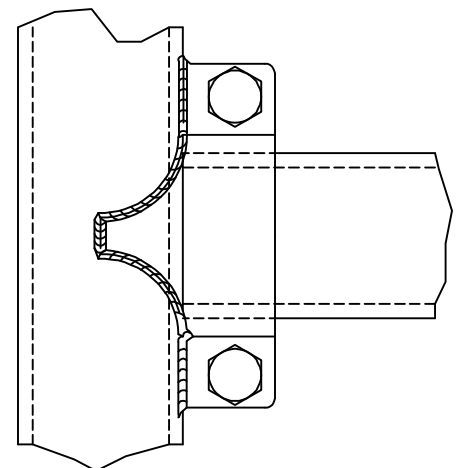

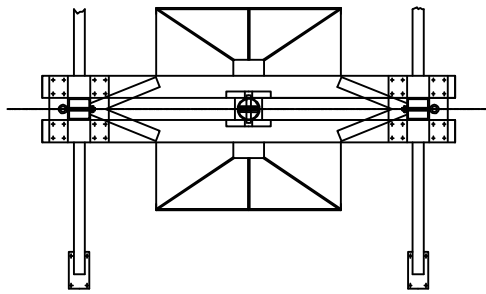
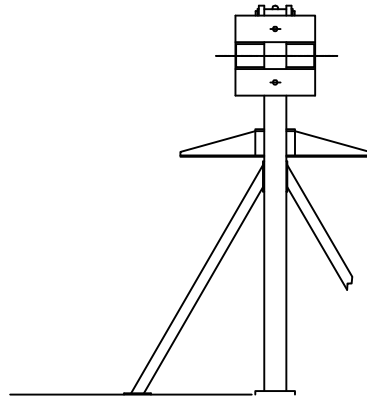
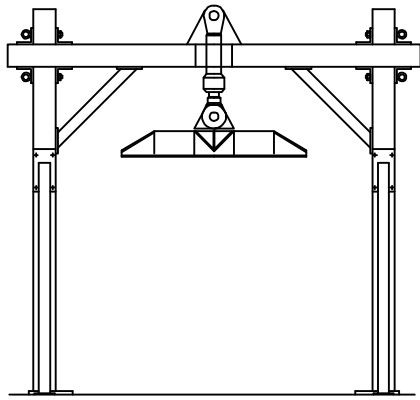

Dessin / Drawing N° 253-38

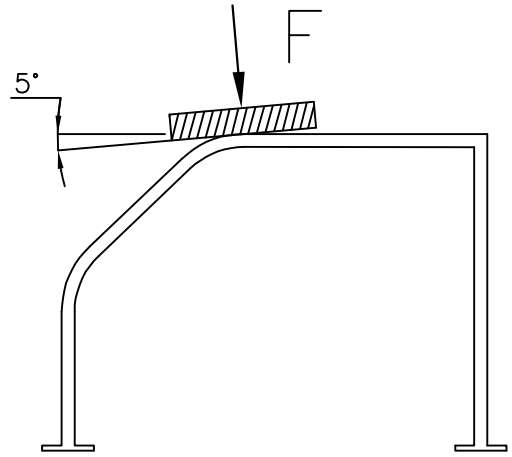
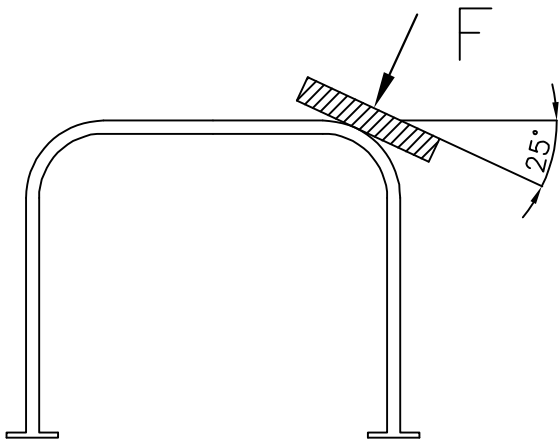

Dessin / Drawing N° 253-38B

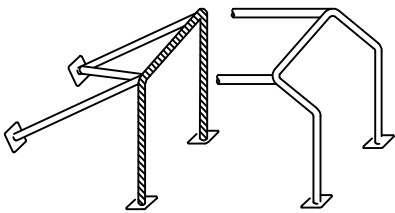

Dessin / Drawing N° 253-39

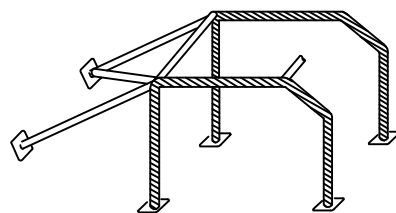

Dessin / Drawing N° 253-40

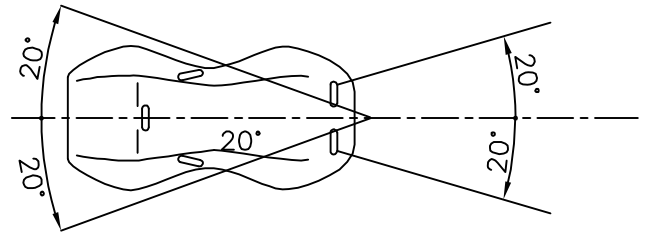
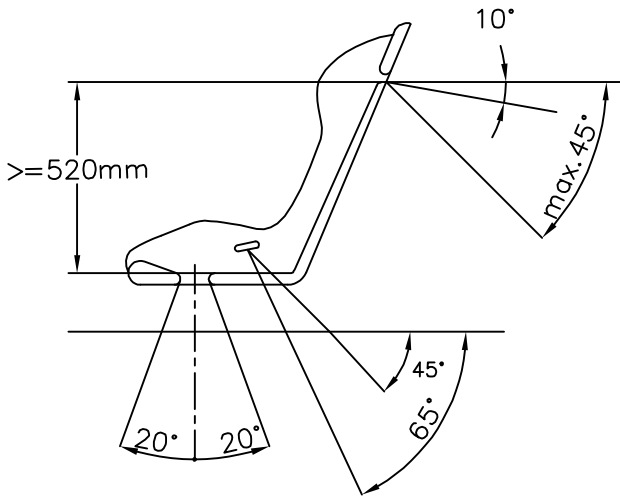

Dessin / Drawing N° 253-42

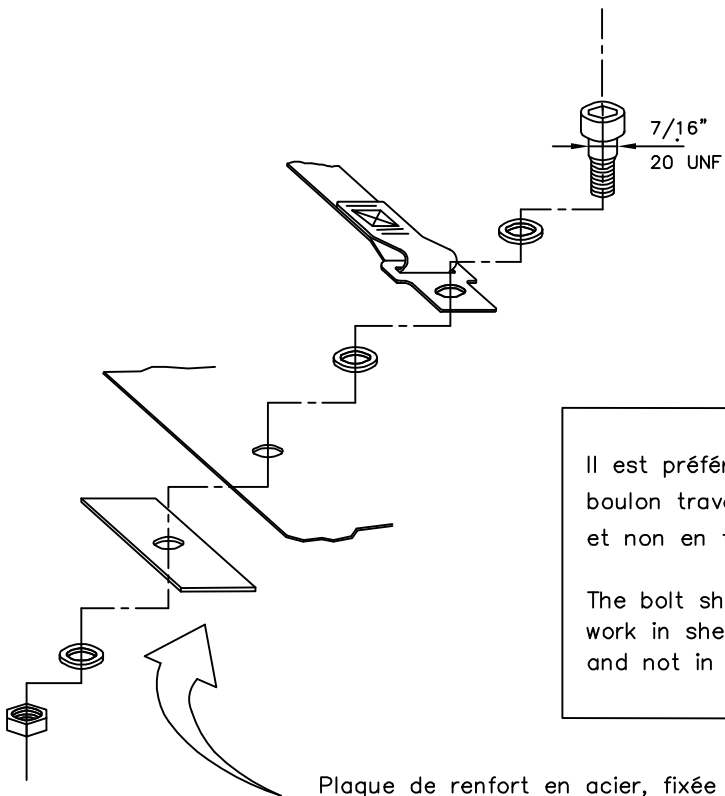

Il est préférable que le  
boulon travaille en cisaillement  
et non en traction

The bolt should preferably  
work in shearing stress  
and not in traction

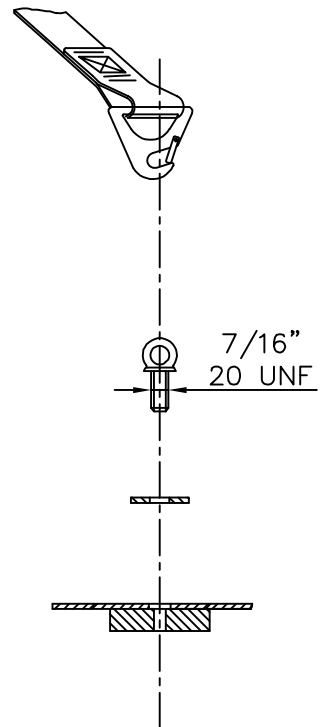

Plaque de renfort en acier, fixée  
au châssis de la voiture  
Steel reinforcing plate fixed  
to the car's chassis

Dessin / Drawing N° 253-43

plaque fixée au châssis de la voiture et renforcée  
de l'autre côté par une plaque de renfort

plate fixed to the chassis and strengthened  
by a reinforced plate on the other side

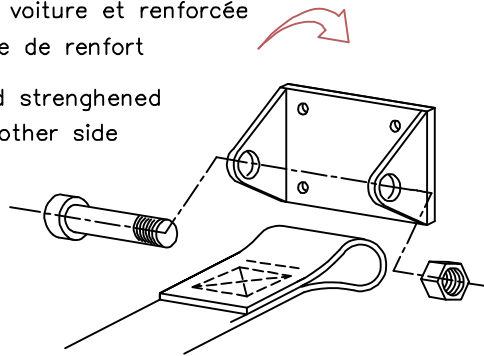

Dessin / Drawing N°253-44

plaque de renfort fixée au châssis de la voiture  
reinforcing plate fixed to the car's chassis

renfort / reinforcement

coque du siège  
seat shell

contre-plaque  
conterplate

contre-plaque  
conterplate

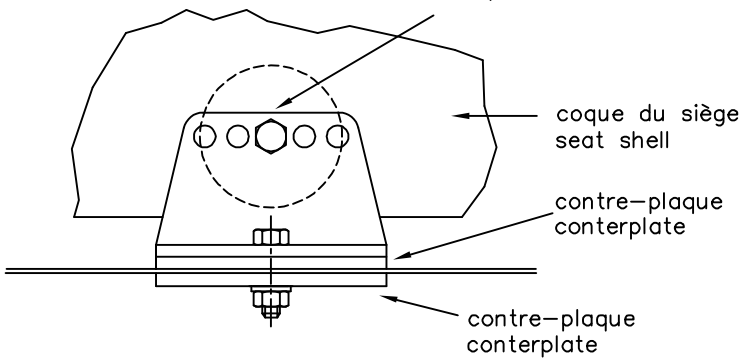

Dessin / Drawing N°253-52

Dessin / Drawing N°253-45

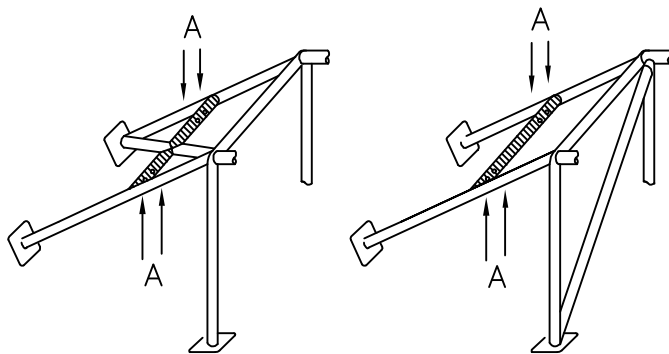

Ⓐ trous de montage pour harnais  
mounting holes for harness

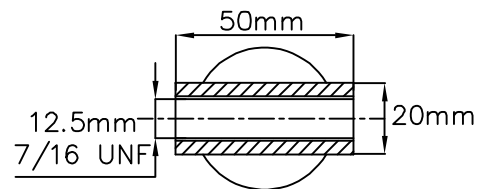

Agrandissement de A  
Magnification of A

Dessin / Drawing N°253-53